



How to choose the right LEDs for Lighting Applications

David Cox

November 8, 2011



CREE 

Lighting-Class LEDs are Not One Product

Lighting Is Not One Application



Driving Lumen Affordability with Technology

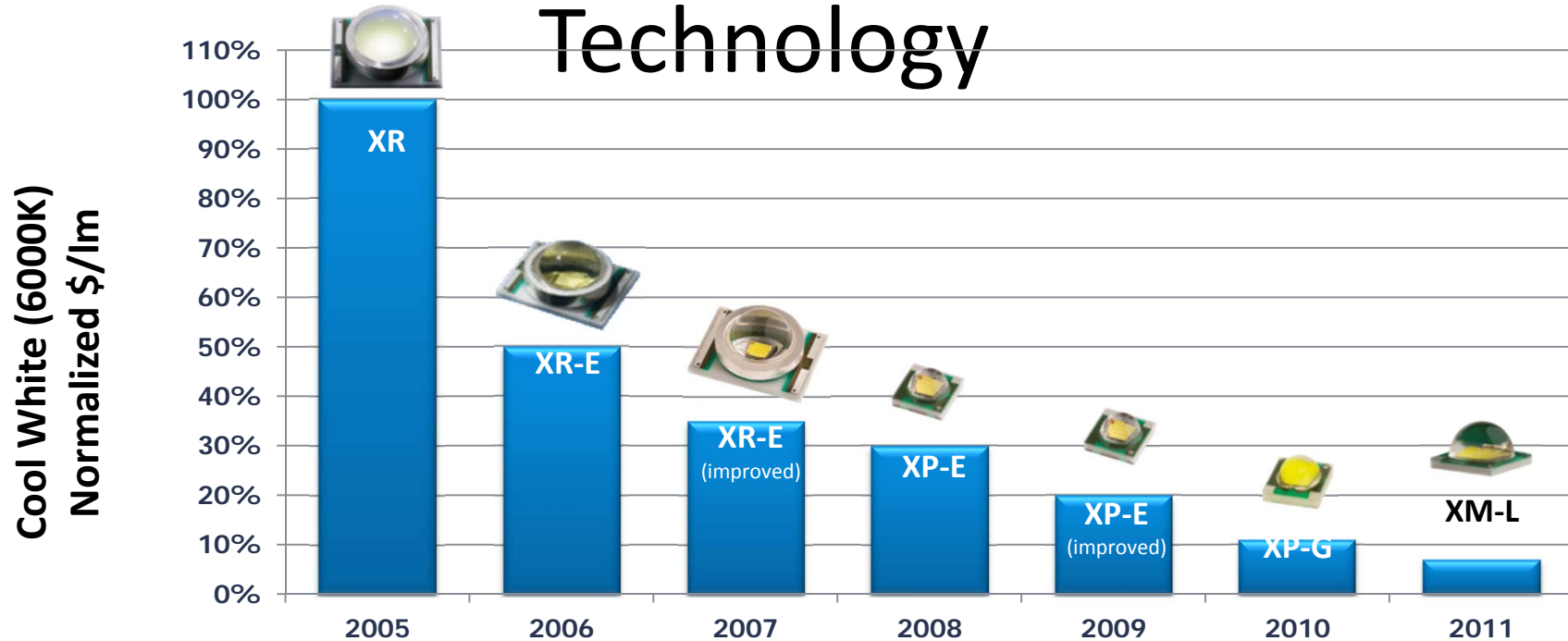

\$/lm Change		-50%	-30%	-14%	-33%	-45%	-36%
Efficacy*	50 LPW	50 LPW	60 LPW	73 LPW	78 LPW	81 LPW	90 LPW
Increase (LPW)		0%	20%	46%	56%	62%	80%

* At maximum drive current (except XR)

Cree SiC LEDs Deliver Lowest System

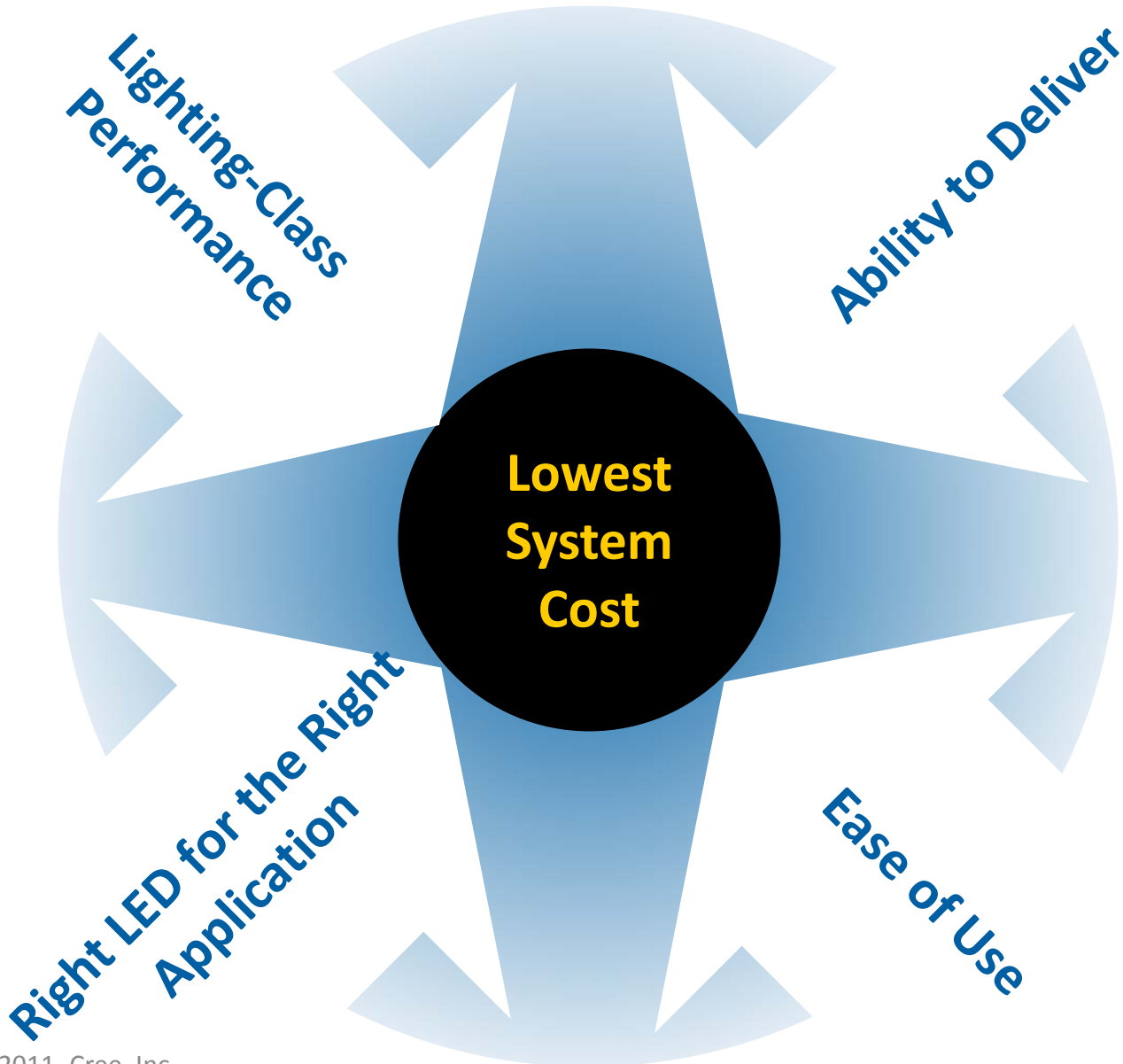

Not a Binning Problem (Poor LED Selection)

Time zero



The LED Matters 1000 hours

LED Puck
84.1% Drop



16.5" Linear
97.8% Drop

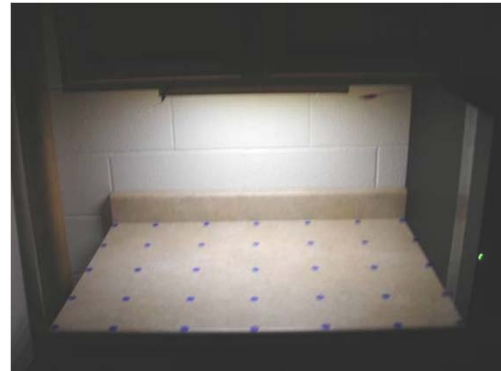

22" Linear
96.9% Drop



Lighting Applications Have Varied Requirements











Value →

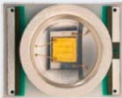
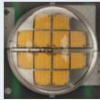

		OUTPUT & CONTROL		QUALITY OF LIGHT		RELIABILITY	
		Flux and Efficacy	Optical Control	Color Quality (CRI)	Color Consistency	Color Stability	Lumen Maintenance
INDOOR	Omnidirectional, A-bulb						
	Accent, Track, PAR, MR bulb						
	Ceiling-mounted, Recessed						
	Linear, Commercial, Retail						
	Industrial, High Bay						
OUTDOOR	Roadway, Parking, Bollard						
	Landscape						
PORTABLE	Consumer						
	High-end, High-output						

Cree Lighting LED Components

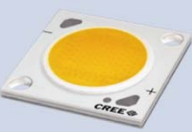
EASE OF USE

	DISCRETES	ARRAYS	MODULES
DIRECTIONAL	 <p>XM-L</p>  <p>XP-G XP-E XP-C</p>  <p>XR-E XR-C</p> <p>PERFORMANCE</p>	 <p>MT-G</p>  <p>MP-L</p>  <p>XM-L EZW</p>  <p>MC-E</p> <p>PERFORMANCE</p>	
NON-DIRECTIONAL	 <p>XP-E HEW</p>  <p>MX-6 MX-3</p>  <p>ML-E ML-B</p> <p>PERFORMANCE</p>	 <p>CXA20</p> <p>PERFORMANCE</p>	 <p>LMR4</p>  <p>LMR2</p> <p>PERFORMANCE</p>

Lighting Applications Matrix for Cree LEDs

	DISCRETES		ARRAYS				MODULES	
Indoor								
Non-directional A & E Bulbs, Sconces	 MX-6	 XP-E HEW	 CXA2011					LMR4 LMR2
Directional MR & PAR, Spot, Track	 XP-G XP-E	 XM-L	 XM-L EZW	 MC-E	 MT-G	 MP-L		LMR2
Downlight Ceiling Mount, Pendant	 MX-6	 XP-E HEW	 MP-L	 CXA2011				LMR4 LMR2
Distributed Cove, FL Retrofit, Panel	 ML-E ML-B	 MX-6 MX-3						
Low & High Bay Warehouse, Industrial	 XP-G	 XM-L						
Outdoor								
Roadway & Parking Street, Tunnel, Garage	 XP-G	 XM-L						
Exterior Area Bollard, Wall Pack	 MX-6	 XP-E HEW	 CXA2011					LMR4 LMR2
Landscape	 ML-E		 MT-G					
Portable								
Mainstream	 ML-E	 XP-E XP-C						
High End Search, Lantern, Spot	 XR-E	 XP-G XP-E						

Best Performance for Low System Cost

Design Performance
Highest Efficacy
Lowest Input Power
Highest CRI
Highest Power Factor
Variety of Color Temperatures
Driver Efficiency
Excellent Dimming
Versatile Form Factor

System Costs

Smallest Upfront Cost
Decreased Design Complexity
Increased Design Re-use
Lowest Manufacturing Complexity
Fewest Part Suppliers
Smallest Part Inventory

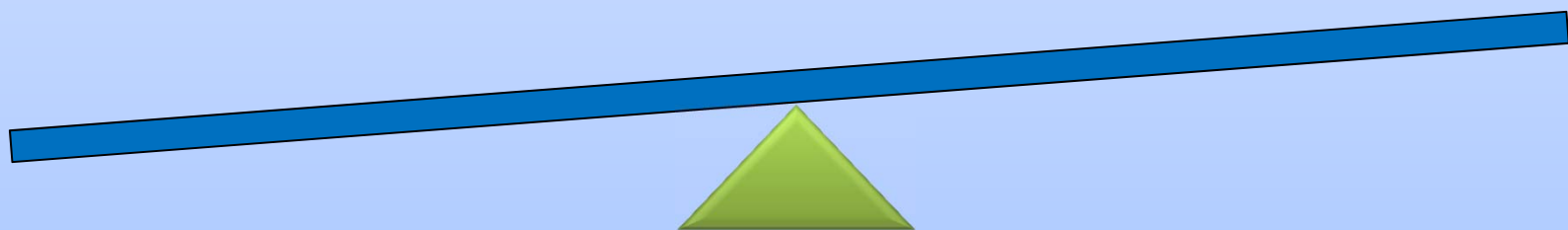

Benefits

- No color-mixing or binning issues
- Simplified supply chain & inventory requirements
- Lowest upfront cost/risk

- Design flexibility
- Maximum optical control
- Form factor flexibility
- Lowest BOM cost

**Luminaire
Manufacturer
Profile**

- Lower time to market pressure
- Have LED & driver expertise
OR
Willing to outsource light engine design & driver supply

- Need to make a broad play into LED market quickly
OR
New to LED design

**COMPONENTS &
ARRAYS**

MODULES

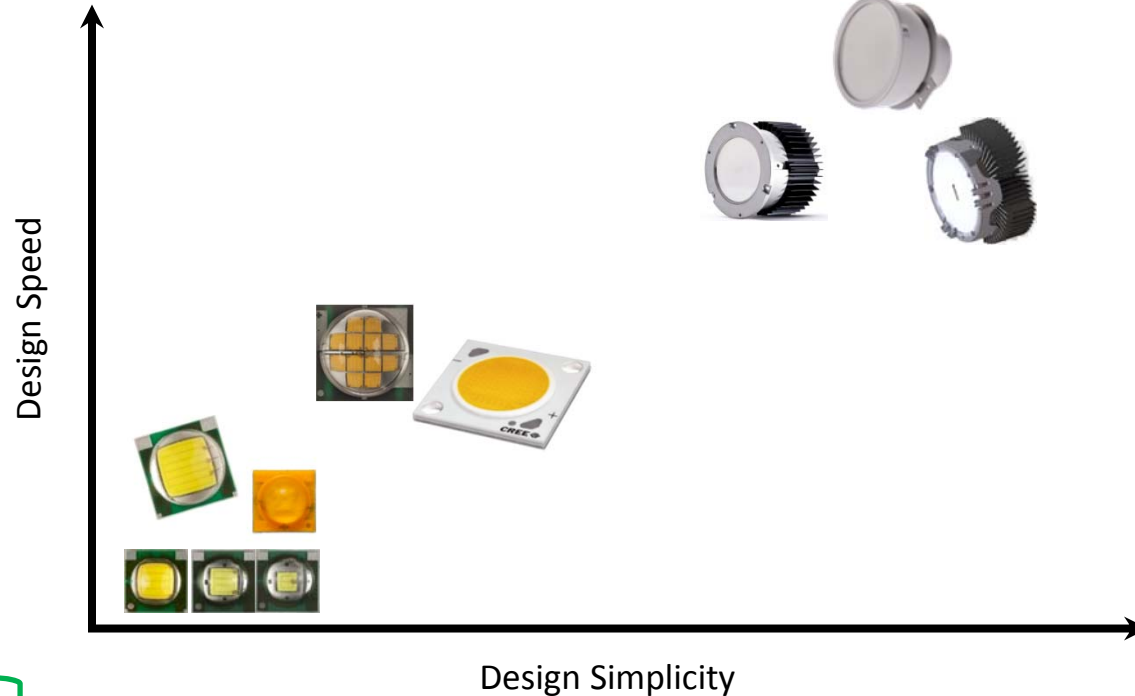

LED Capacity Concept

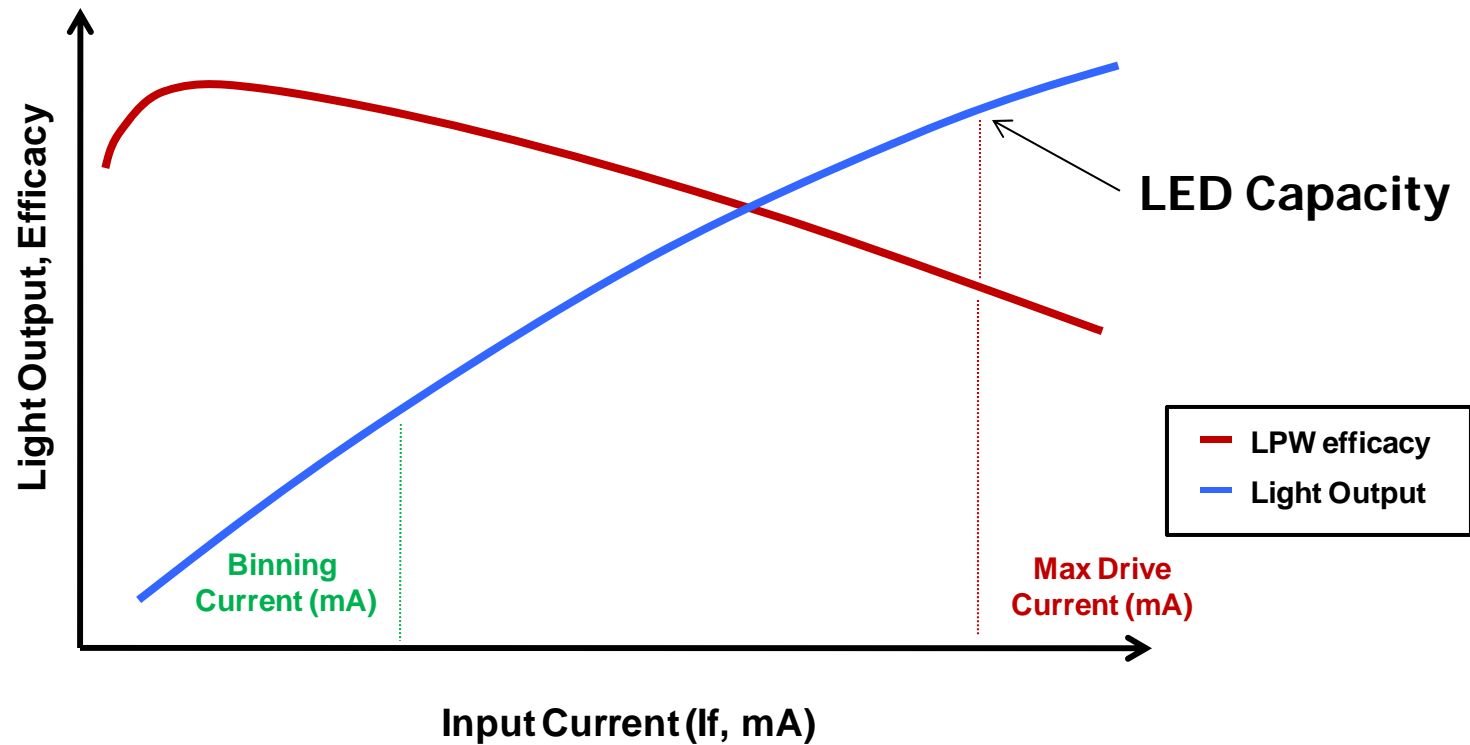

This Trade-Off Is An Opportunity To Lower System Cost

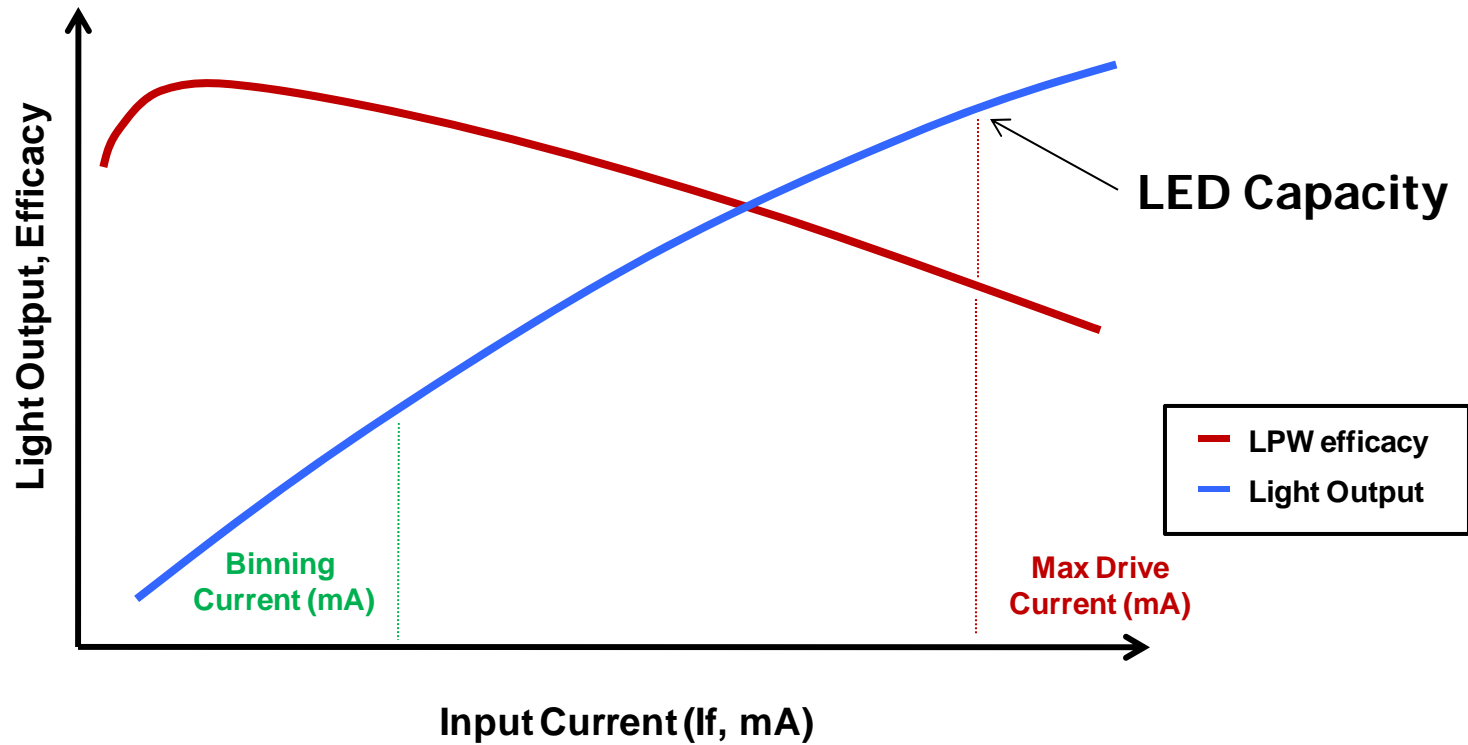

- Capacity of LED is Luminous Flux @ Max Drive Current
 - Running above binning current is not “over-driving” the LED...

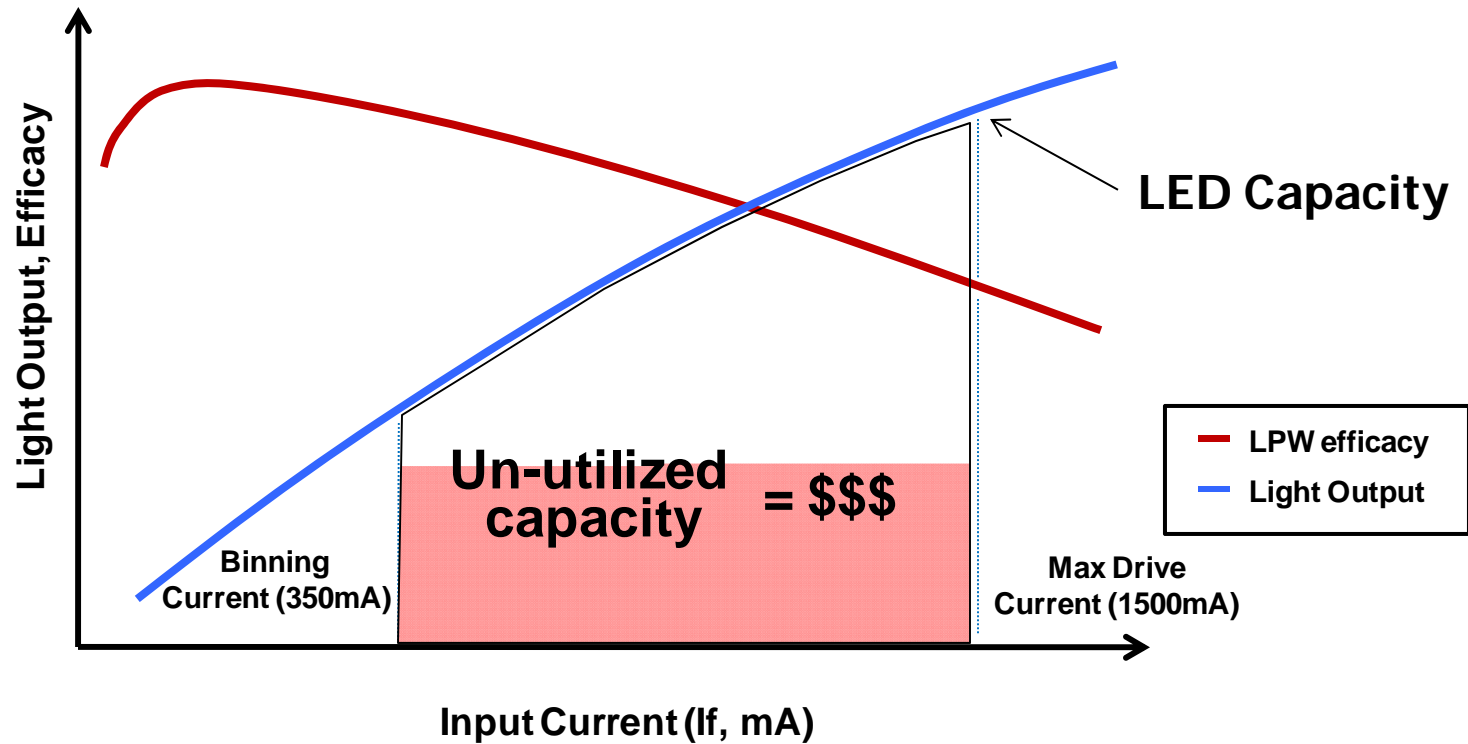

- At the binning current only 23% of the capacity of this LED is utilized; 77% of the LED goes UNUSED! (These are wasted lumens)
- There are, of course, practical limitations to this...
 - ENERGY STAR efficacy requirements
 - LED L70 lifetime
 - System thermal capacity

Good design: Balance design trade-offs

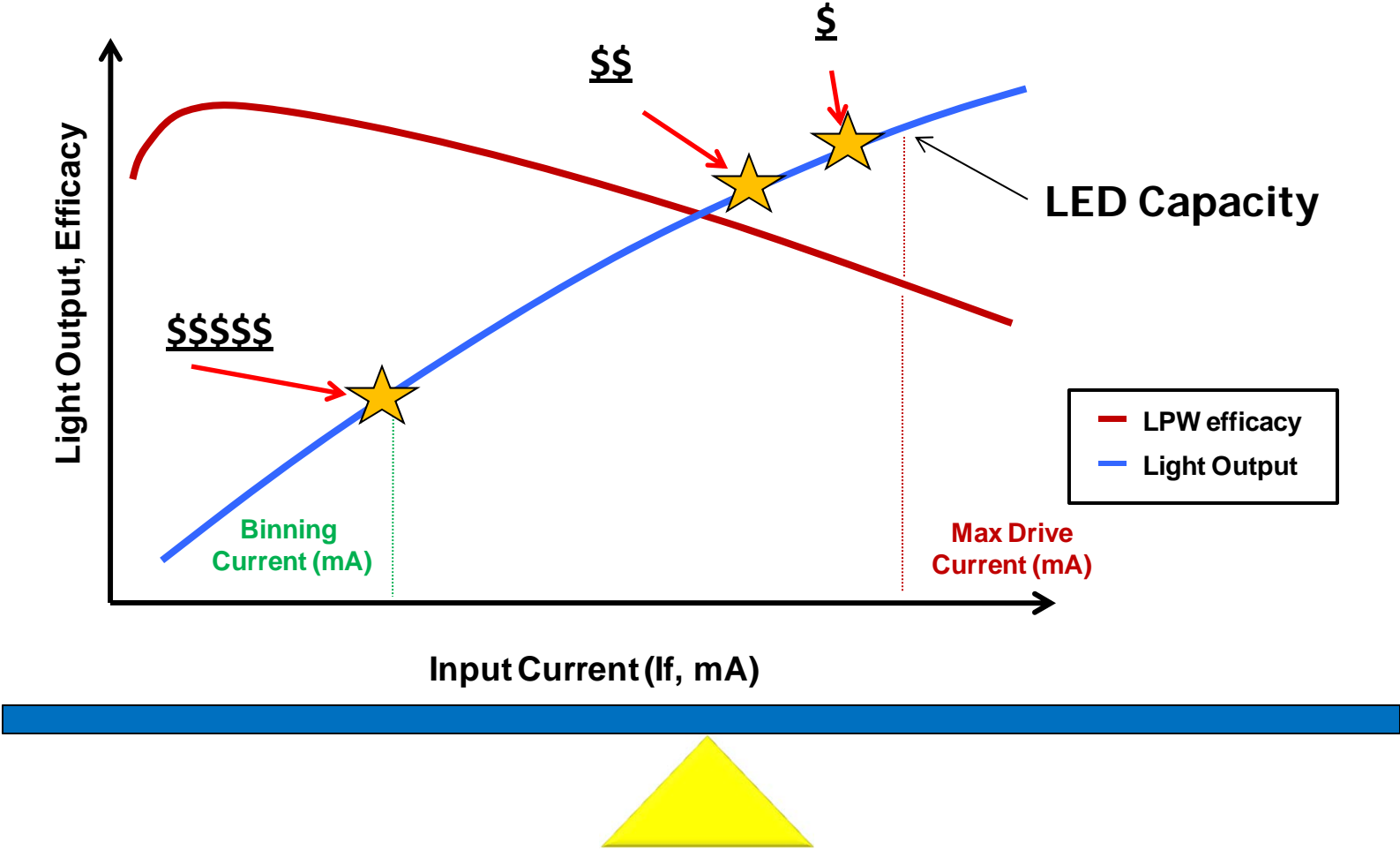

Cree enables you to optimize your design by matching the right LED for the application (Price/Optical/Voltage/integration)

Other Capacity Limits – Energy Star

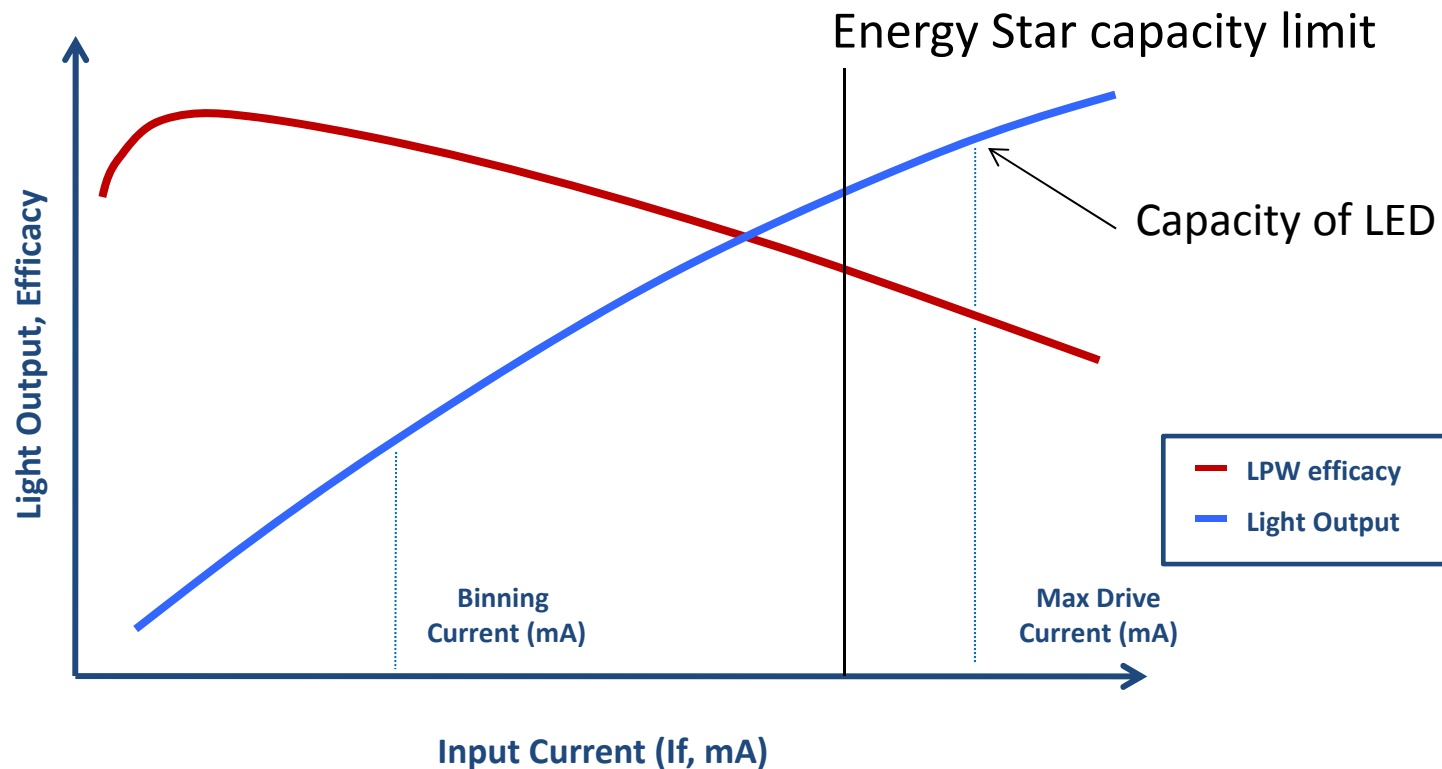

- Energy Star Requirements may be the capacity limit
- Energy star potential capacity limits:
 - LM80 test data
 - System efficacy minimum

Other Capacity Limits – Thermal



(MR16, MT-G)

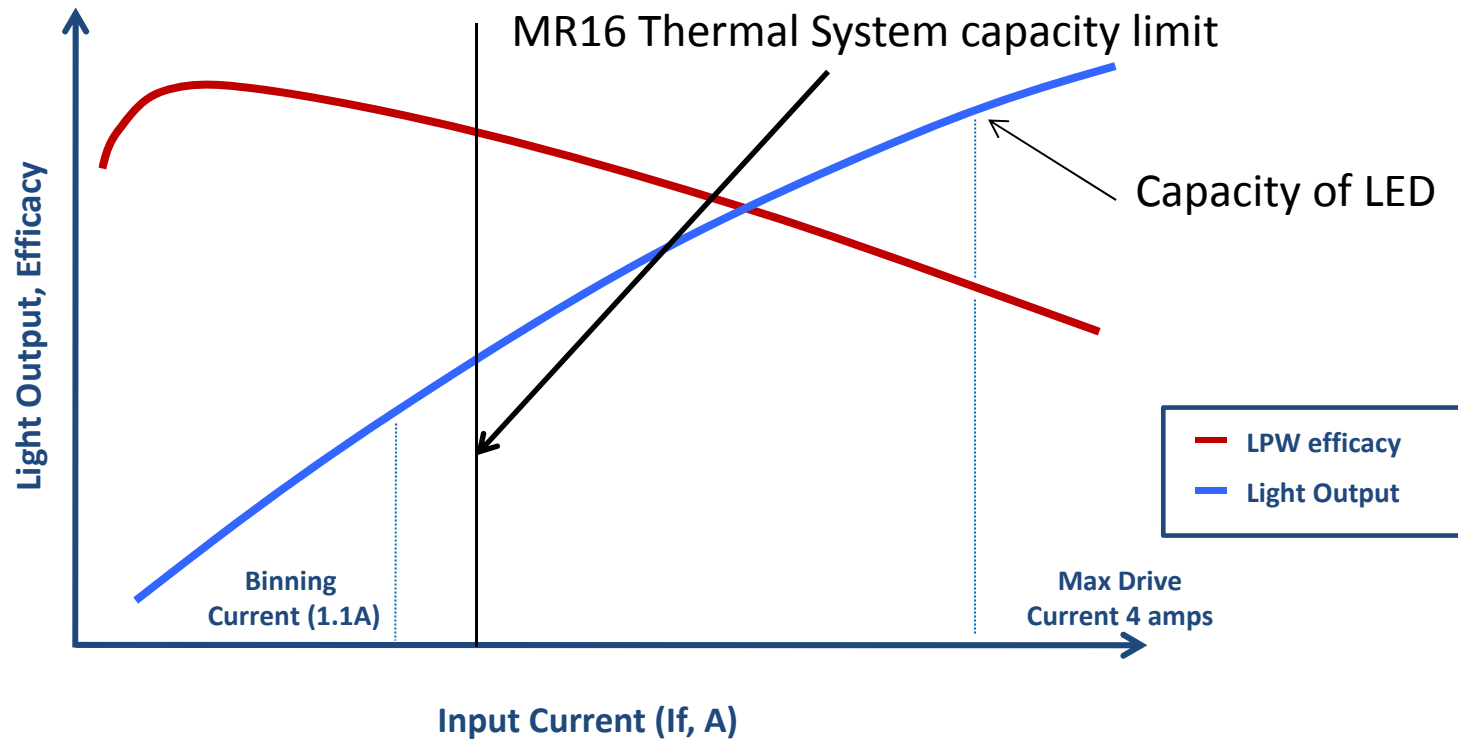

- System Thermal capacity is the limiting factor !

Choose Lighting Class LEDs

- Choose LEDs with high capacity to lower your system cost

XLamp XP-G

up to **493 lm @ 5W**

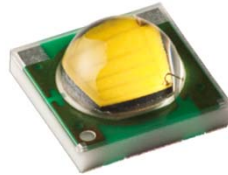

XLamp XM-L

up to **1000 lm @ 10W**



XLamp MT-G

up to **1525 lm @ 24W**

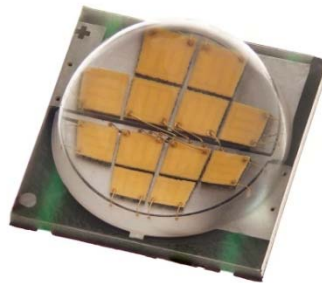

XLamp CXA2011

up to **4000 lm @ 47W**



- Understand how LEDs will behave at currents different than binning current

XLamp XP-G White L70 Lifetime (TM-21)

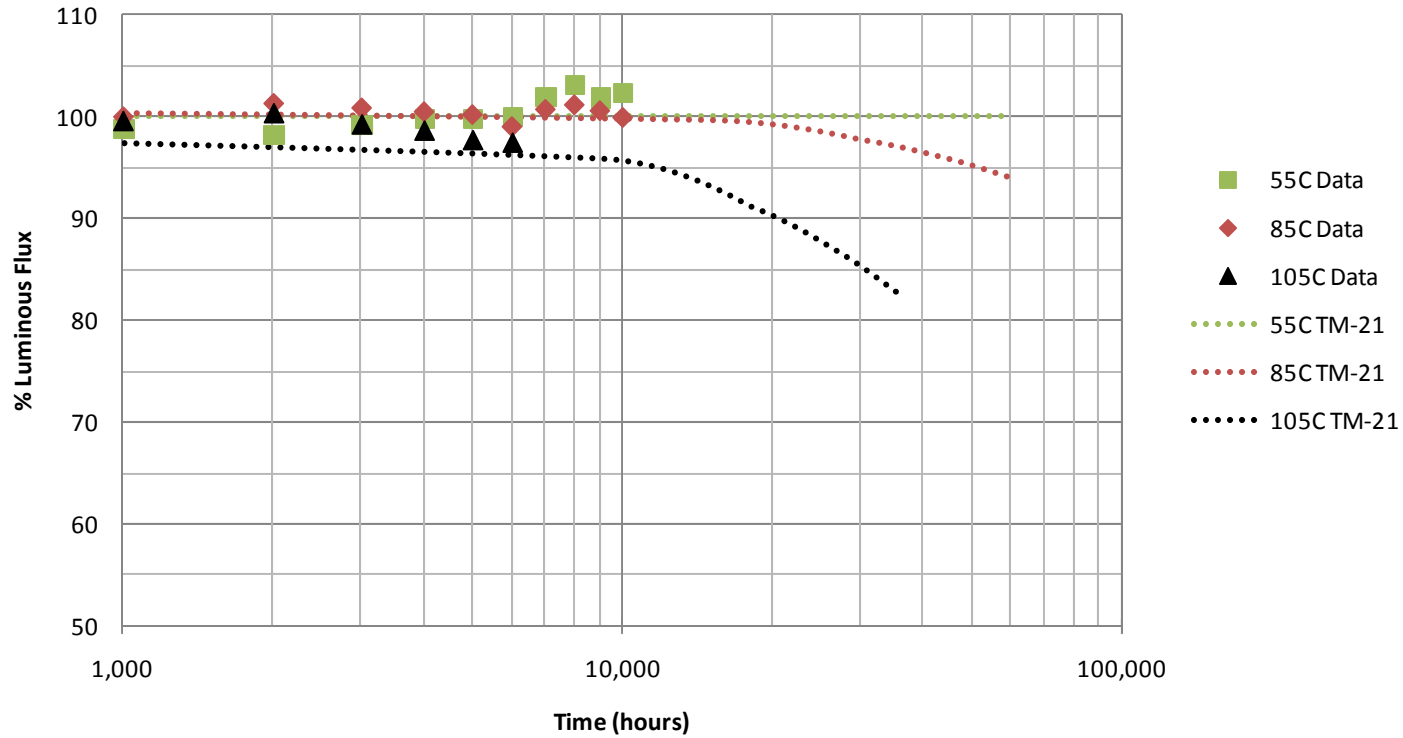

Current	Ta/Tsp	Test Duration	α	β	Calculated L70	Reported L70
1000 mA	55°C	10,080 hrs	-4.219E-06	9.847E-01	---	L70 (10k) > 60,500 hrs
1000 mA	85°C	10,080 hrs	1.284E-06	1.016E+00	290,000 hrs	L70 (10k) > 60,500 hrs
1000 mA	105°C	6,048 hrs	5.561E-06	1.007E+00	65,500 hrs	L70 (6k) > 36,300 hrs

Notes:

- These extrapolations are for informational purposes only and are not a warranty or a specification.
- Extrapolated lifetimes are subject to change without notice.

XLamp XM-L White L70 Lifetime (TM-21)

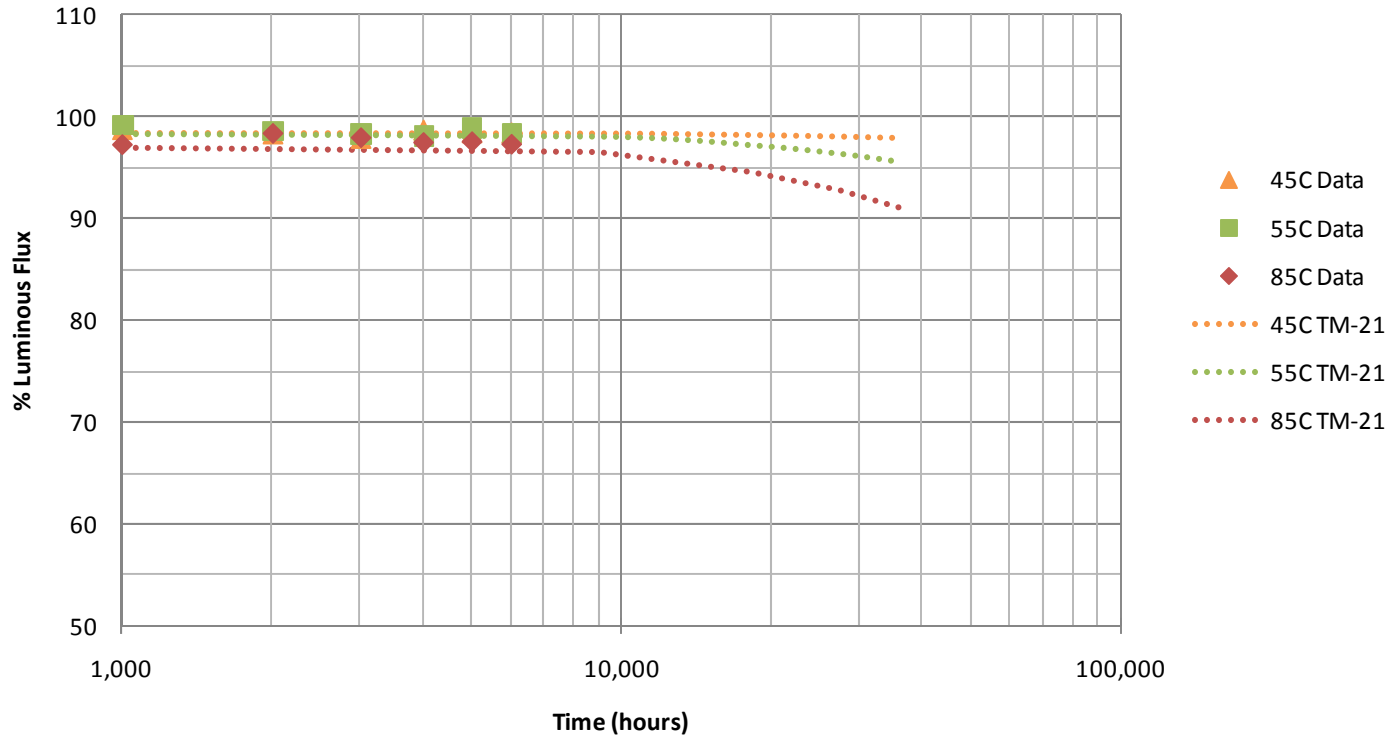

Current	Ta/Tsp	Test Duration	α	β	Calculated L70	Reported L70
2000 mA	45°C	6,048 hrs	1.459E-07	9.847E-01	2,340,000 hrs	L70 (6k) > 36,300 hrs
2000 mA	55°C	6,048 hrs	9.543E-07	9.887E-01	362,000 hrs	L70 (6k) > 36,300 hrs
2000 mA	85°C	6,048 hrs	2.155E-06	9.834E-01	158,000 hrs	L70 (6k) > 36,300 hrs

Notes:

- These extrapolations are for informational purposes only and are not a warranty or a specification.
- Extrapolated lifetimes are subject to change without notice.

Design Check List LED/Module Selection

1. Regulatory / Voluntary (ENEC, CE, UL, Energy Star, title 24...)
2. CCT
3. Lumens (Light on target
4. Color (CRI, color consistency, color shift)
5. Temperature (Operating & Tsp for Lifetime, Warranty)
6. TM21 based operating point (Vf and drive current)
7. Cree Product Positioning handout
8. Data sheet/PCT
9. Binning Labeling
10. Soldering handling
11. Optical solution- Source Size (Etendue)
12. Select Product Family (component / Module)
 - Time to market
 - Internal expertise
 - Price

Example of Application Optimized LED

- Need 300 lumens
- Input voltage Line voltage..
- Should I use 3V LED – so many parts??
- What should I do

XLamp[®] High Voltage White

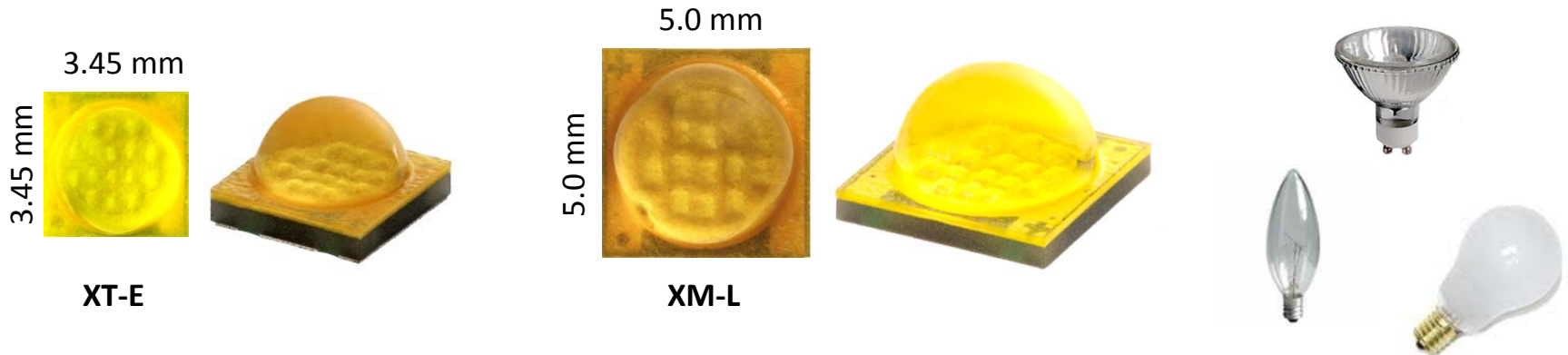

Highest performance available in discrete-size HV LEDs

- 46V drop in the size of a discrete LED (15-40x smaller than arrays)
 - Enables the use of lower cost, smaller size and higher efficiency LED drivers
 - Provides more room for LED driver & heat sink in space-constrained designs
- Right combination of flux & efficacy to enable 25W & 40W B10
 - One XT-E = 25W replacement; One XM-L = 40W replacement
- Optimized for non-directional lighting & small LED replacement lamps (B10, GU10, E17, A19)

Why HV LEDs Make Drivers More Efficient

- Most basic building block: Rectifier + LED

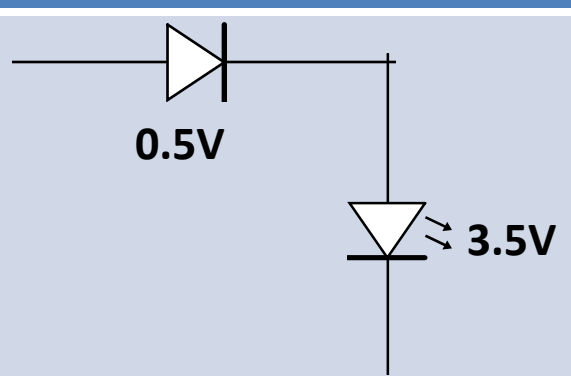
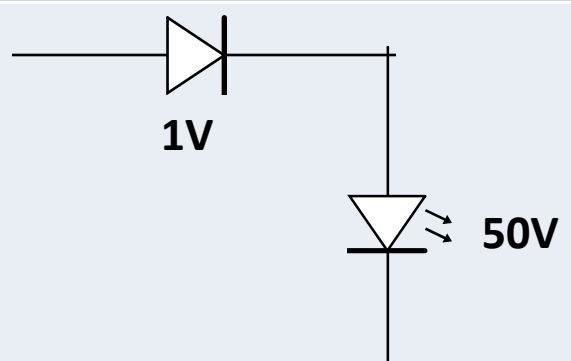
Total Voltage	Schematic	System Efficiency
4V	 <p>A schematic diagram showing a diode with a 0.5V drop in series with an LED that has a 3.5V drop. The total voltage across the series combination is 4V.</p>	$3.5V / 4V = 87.5\%$
51V	 <p>A schematic diagram showing a diode with a 1V drop in series with an LED that has a 50V drop. The total voltage across the series combination is 51V.</p>	$50V / 51V = 98\%$

**High voltage yields 10.5 percentage point improvement
in the most basic system (LED + Diode)**

HV LEDs Make Driver Smaller & More Efficient

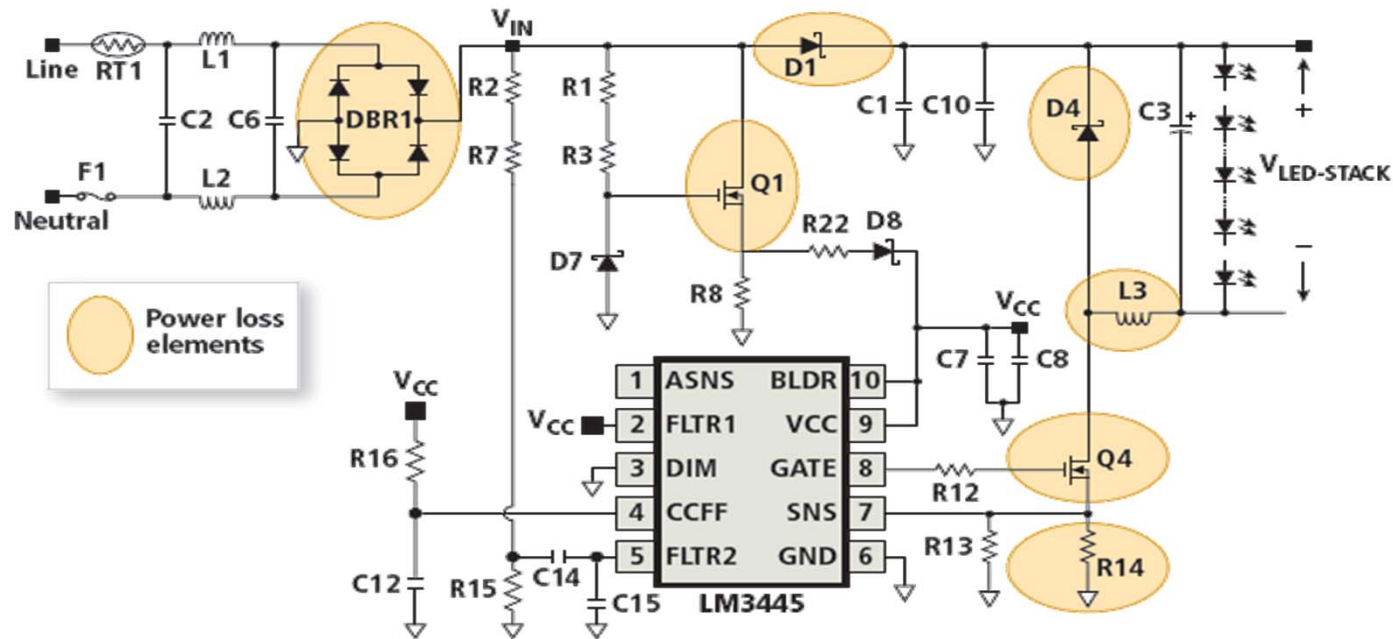

Component	% smaller	% more efficient	% lower cost	% lower temp
Bridge	Same	0-10%	Same	0-25%
Diode	0-50%	50%	50%	10-25%
FET	25%	25%	25%	10%
Inductor	30%	50%	20%	30%
Overall	15%	10-20%	10%	10%

Less Power Waste = More Lumens!

In a shared heat sink system,
heat from the power supply lowers the LED Lumens

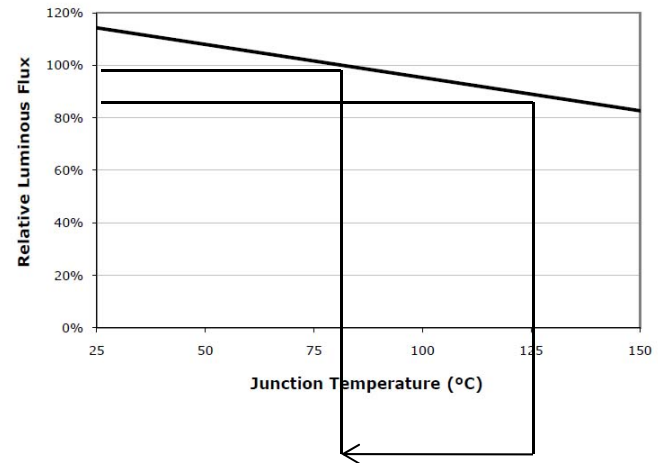
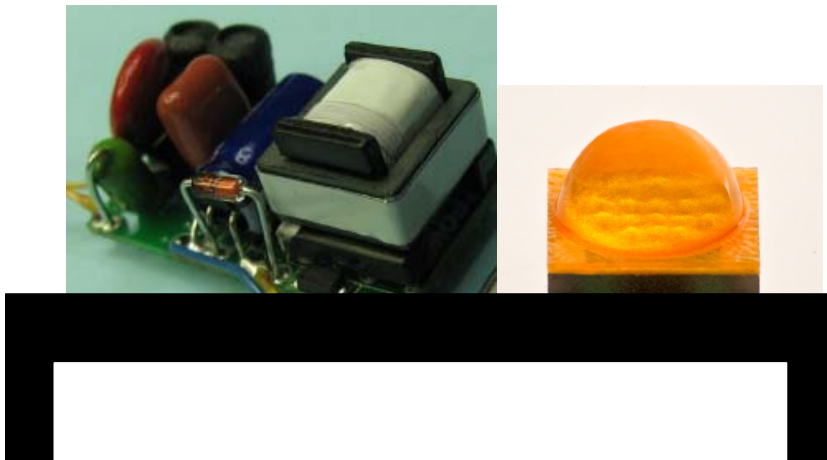

Application: B10 Candelabra

Design Target:

- 200 lm (25W), 300 lm (40W)
- 3000K CCT
- 85% optical efficiency
- 90% electrical efficiency
- $T_{sp} = 85^{\circ}\text{C}$
- 5W maximum power
- Reference Design Available







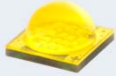

B10 Equiv.	LED			System		
	Model	# LEDs	Electrical	Lumens	Power	Efficacy
25W	XLamp XM-L EasyWhite	1	11.6 V, 340 mA	204 lm	4.1W	50 LPW
	XLamp XT-E High Voltage	2	95.7 V, 43.8 mA	235 lm	4.9W	48 LPW
40W	XLamp XM-L High Voltage	1	48.8 V, 92.3 mA	292 lm	5.2W	57 LPW

XLamp High Voltage LEDs – Summary

- Cree XLamp XT-E HVW & XM-L High Voltage White LEDs are the highest performance High Voltage LEDs in the marketplace
- Eliminate trade-off between size and efficacy – First High Voltage LEDs with similar efficacy to corresponding size, standard voltage discrete LEDs
- Enable driver circuits that are up to 15% smaller, 20% more efficient, 10% lower cost and 10% cooler
- Offer the right combination of flux and efficacy to enable LED replacements for 25 W and 40W B10 Candelabra Bulbs

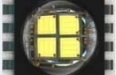
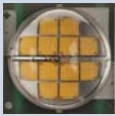
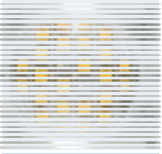
Cree's High Voltage Portfolio

	XLamp		Voltage (V)	Max Power (W)	Size (mm)	Applications
Discretes	XT-E High Voltage		48	3	3.5 x 3.5	Retrofit lamps
	XM-L High Voltage		48	6	5 x 5	Retrofit lamps
	MX-3S		10 – 12	2	5 x 6	A Bulbs up to 40W
	MX-6S		20 – 24	3	5 x 6	A Bulbs up to 40W
Arrays	XM-L EasyWhite		6 – 12	10	5 x 5	GU10/MR16
	MC-E		3 – 13	10	7 x 9	GU10/MR16
	MT-G		6 – 36	24	9 x 9	GU10/MR16 / PAR
	MP-L		24 - 82	20	12 x 13	PAR
	CXA2011		42	27	22 x 22	Downlights/ 60W+ Bulbs