

WPG WPG Americas Inc.
Lighting Solutions



Anatomy of a Solid State Lighting Design



Introduction – John Grant

- Current Position
 - WPG Americas
 - Centralized Lighting Solutions Engineering
 - Education: UNCC B.S.E./M.S.E. 1983/1985
 - Electrical/Electronics Design Engineer
 - Computer Systems (IT)
 - Field Applications Engineer (since 2000)
 - 10 Years Experience with High Power LEDs
- WPG Americas
 - WPG Holdings \$13B Global Electronic Component Distributor
 - Relatively new in North America (2 years)
 - Fastest growing North American Distributor

- Thesis
 - Recognizing the huge business opportunity solid state lighting will generate in the next 10 years, the traditional electronics engineering and manufacturing industries will need to understand and adapt to the SSL market requirements.
 - Translation: The customer is always right
 - Related Conclusion: Ignorance is NOT bliss...

The End Customer and Application

- Traits of Authentic Customers/Applications
 - Usually substantive economic concerns
 - Power Costs/Availability
 - Maintenance Costs
 - Reliability (with costly consequences)
 - The Payoff Calculation makes sense
 - Intrinsic value of LEDs matches the application
 - Vibration, no-IR, no-UV, small source, etc.
 - End Customer Funding
 - Ready to invest because of material advantage switching to SSL
 - Clear channel to market: often with conventional fixtures
- “Green” Environmental Requirements
 - Tends to not provide sole justification for long term business
 - Might lead to significant publicly funded pilot projects



Courtesy of CREE

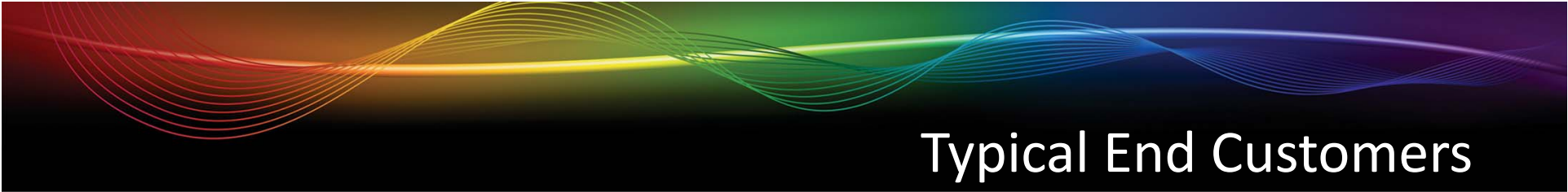

Typical End Customers

- Many new end-customers considering SSL
- Often subjective understanding of lighting
 - That’s cool...that’s what I want
 - May not have deep technical grasp of lighting terminology and specifications
 - The end-customer may not have sufficient knowledge to provide a comprehensive specification that directs & protects the OEM/Developer from pitfalls

End Customer Expectations

- Supply chain based on Lighting industry norms
 - near zero lead-time historically
 - Light Source (Bulb/Tube) sourced from a separate supply-chain from fixture
 - out of necessity for replacements
 - Semiconductor and Lighting Universes Collide

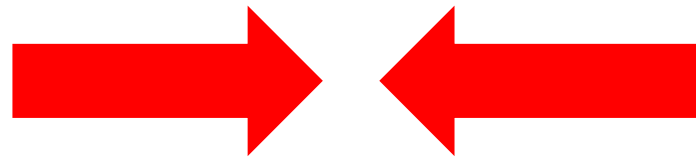

Helping Customers

- Don't out-smart the end customer
 - Accept their level of expertise and educate
 - Sell the end-customer on essential features
 - Help them navigate the path to production
- Meet the customer needs
 - Don't layer features of limited value
 - Match the required value
- Build environment for mutual success
 - Include the critical features which protect the customer's long-term interest.



Courtesy of DOE EERE



Courtesy of DOE EERE



Courtesy of DOE EERE

The Necessary Specifications

- Lighting
 - Illuminance: What's actually hitting the target
 - Start from the target and work backwards
 - Avoid Matching Lumens of Conventional Fixtures
 - Required in some applications
 - “Brightness” only leads to seeing spots
 - Avoid subjective assessments
- Environmental
 - Indoor, Outdoor, Enclosed/Open, Electrical
- Lifetime
 - Carefully assess the actual required operating life



Courtesy of CREE

Design Elements: Light, Optics, Power, Thermal

- Light - Lighting Class LEDs
- Optics
 - Secondary Optics: Lenses, Reflectors
 - Tertiary Optics: Diffusers, Planer Lenses and “Clear” Covers
- Power
 - Interface between the LEDs and the Supply (AC or DC)
 - The Weakest link in all SSL systems
- Thermal
 - System to move heat energy from the fixture to the ambient
 - Protects the LEDs AND the Power Supply
- Key to success: **Balance**
 - Equalize value investment in each design element
 - Minimizing investment in one element will force cost increases in the other areas.



Courtesy of CREE

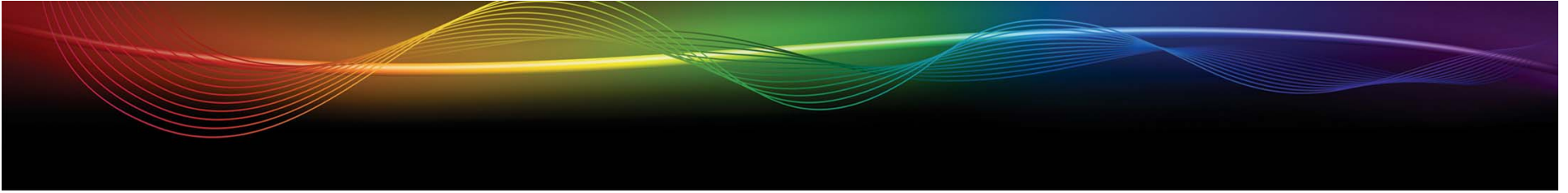

SSL Product Development Cycle

The “Proof of Concept Unit”

- Customer: “How do I **really** know this will work?”
- Good News: Many off-the-shelf components are available
 - LED Starboards
 - Optics: Secondary and Tertiary
 - Power Supplies
 - Heatsinks, Extrusions, Cases (check your local hardware store)
- Beware of “Retrofits”
 - Conventional fixture enclosures by nature make poor LED enclosures
- Do not spend tooling funds on the first unit
 - Use as a step to measure end-customer resolve and build trust
- Great Opportunity to Refine Lighting Specifications



Design Example: Task Light

- Customer required a task light to illuminate desktop
 - Customer did not know required light levels, but had qualitative goals – no shadows, no bright spots, even illumination
- Built concept unit with LED and diffuser samples
- Verified light levels and external appearance



- How hard could it be to drive one of these LEDs?

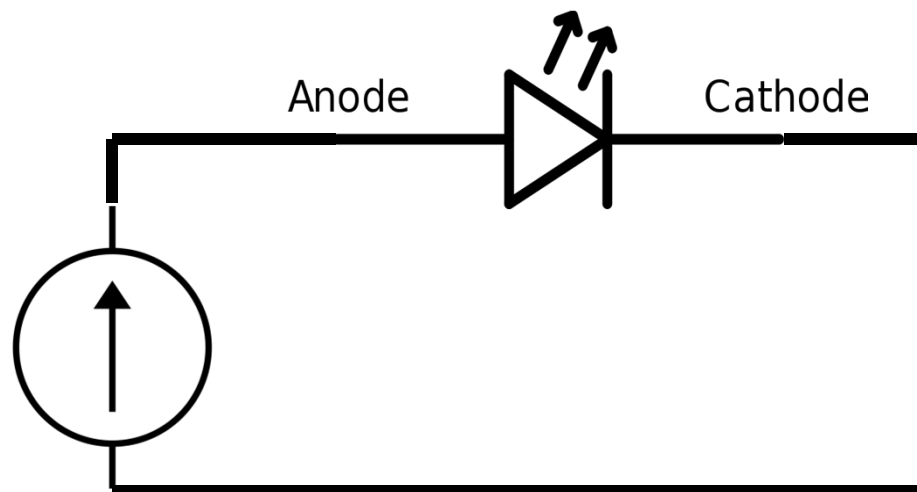

SSL Fixture Block Diagram

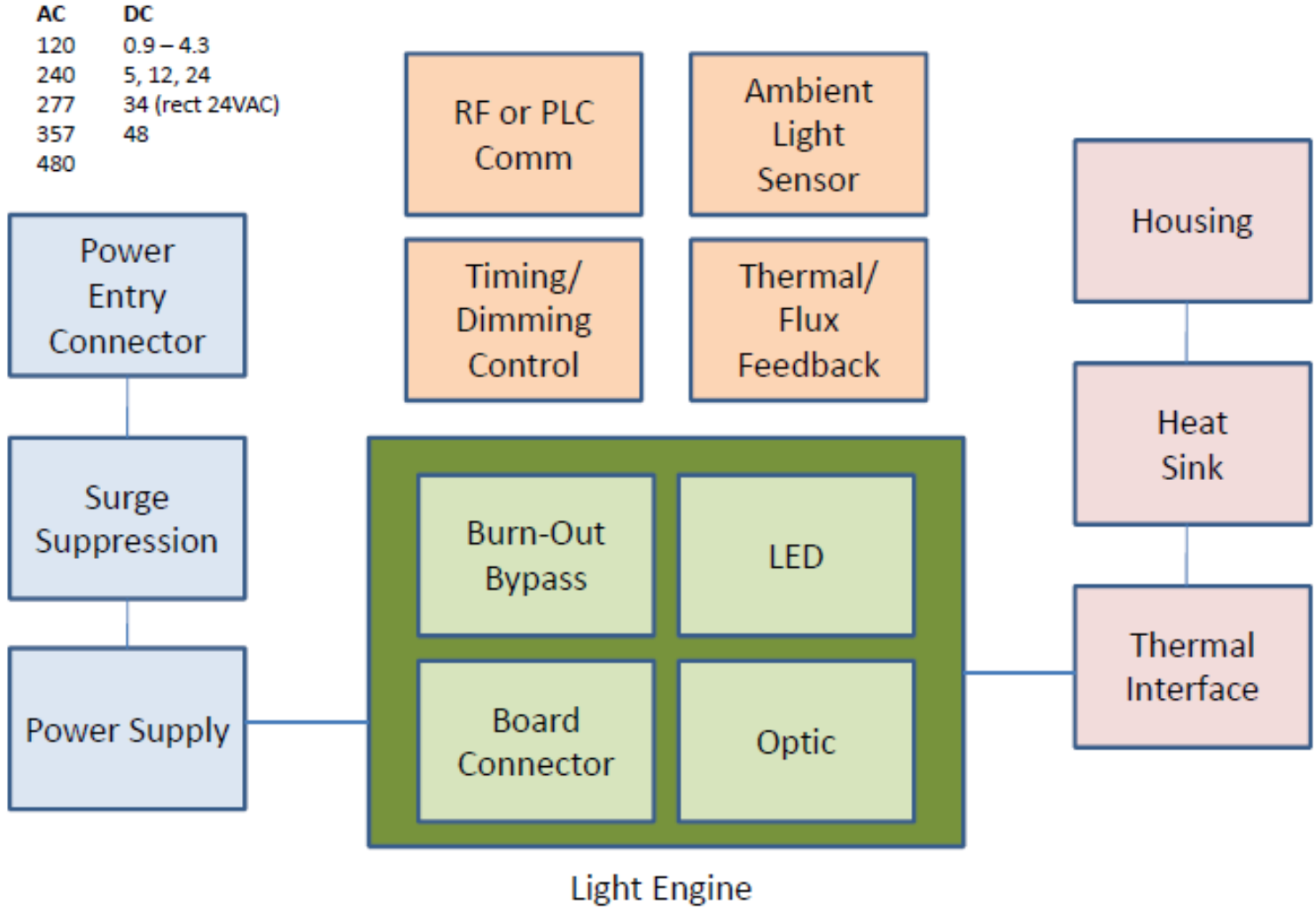

The Light Source: The LED

- Key Selection Criteria
 - LM-80 Testing: Securing the Promise/Capability of long product life
 - Design for LED Availability
 - Binning Flexibility = Availability
 - Design for LED Cost
 - Binning Flexibility = Better Cost
 - Match the LED “Capacity” with the Application

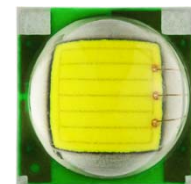
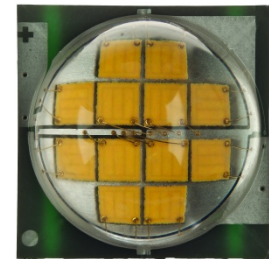

Product Life: LM-80 and TM-21

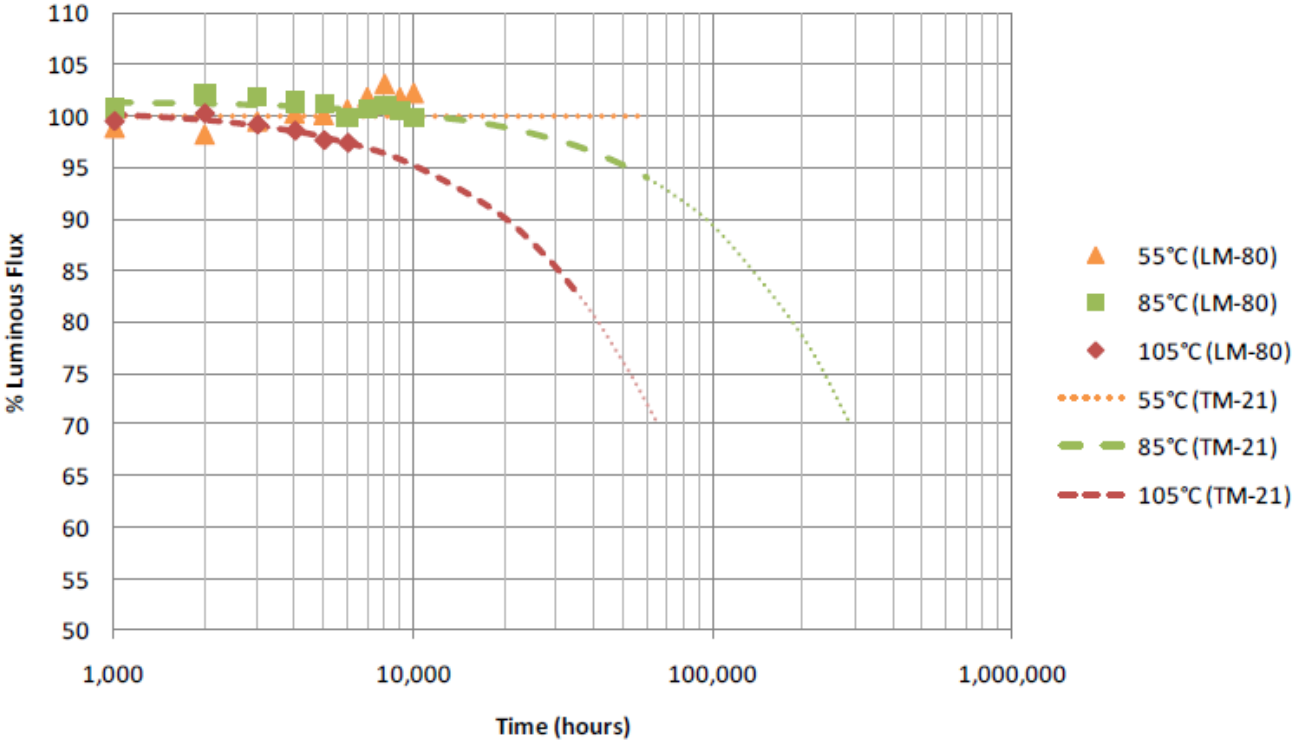

Current	Ta/Tsp	Test Duration	α	β	Calculated L70	Reported L70
1000 mA	55°C	10,080 hrs	-4.219E-06	9.847E-01	---	L70 (10k) > 60,500 hrs
1000 mA	85°C	10,080 hrs	1.284E-06	1.016E+00	290,000 hrs	L70 (10k) > 60,500 hrs
1000 mA	105°C	6,048 hrs	5.561E-06	1.007E+00	65,500 hrs	L70 (6k) > 36,300 hrs

LED Capacity

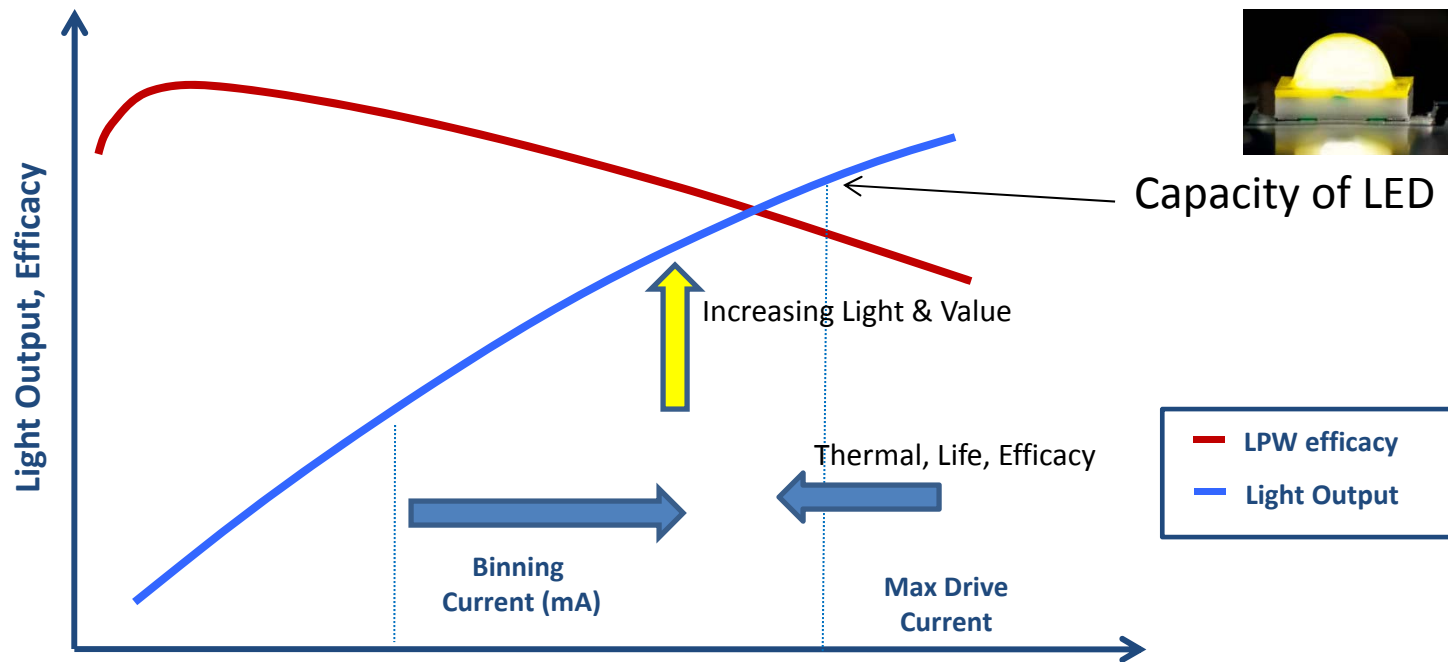

- Pushing operating current toward Max Drive increases value of the LED
- Limit Current to meet key specs
 - Thermal, Lifetime, Efficacy

LED Selection

	DISCRETES		ARRAYS				MODULES	
Indoor								
Non-directional A & E Bulbs, Sconces	 MX-6	 XP-E HEW	 CXA2011					LMR4 LMR2
Directional MR & PAR, Spot, Track	 XP-G XP-E	 XM-L	 XM-L EZW	 MC-E	 MT-G	 MP-L		LMR2
Downlight Ceiling Mount, Pendant	 MX-6	 XP-E HEW	 MP-L					LMR4 LMR2
Distributed Cove, FL Retrofit, Panel	 ML-E ML-B	 MX-6 MX-3						
Low & High Bay Warehouse, Industrial	 XP-G	 XM-L						
Outdoor								
Roadway & Parking Street, Tunnel, Garage	 XP-G	 XM-L						
Exterior Area Bollard, Wall Pack	 MX-6	 XP-E HEW						LMR4 LMR2
Landscape	 ML-E		 MT-G					
Portable								
Mainstream	 ML-E	 XP-E XP-C						
High End Search, Lantern, Spot	 XR-E	 XP-G XP-E						



Avoiding LED Selection Pitfalls

- Verify secondary optic availability for selected LED
 - Off-the-shelf Optic availability lags the introduction of new LEDs
 - Custom Optics
 - Include Optic Designer in LED Selection Process
- Verify product life of LED Component
 - End of Life (EOL) on your LED, could be the EOL of your fixture
 - Very rare event in LEDs
 - Advancing LED Technology may “obsolete” a SSL Design
 - Consider design approaches which permit flexible LED counts
 - Lower flux bins may drop from availability
- Select UL Recognized Components

PCB – The Light Engine

- First Law of SSL Design:
 “Every new fixture design can benefit from optimized PCB”
 - Optimizes LED Count
 - Lifts Constraints on the Current
 - Lifts Constraints on the Optic Count and Size
 - Optimize Optics placement
 - Mechanical Attachment
 - Electrical Connections
 - Design for Manufacturing
- Off-the-Shelf Boards
 - Proof of Concept Units
 - StarBoards: Low Volume Production
- Include PCB Development in SSL Design Plan

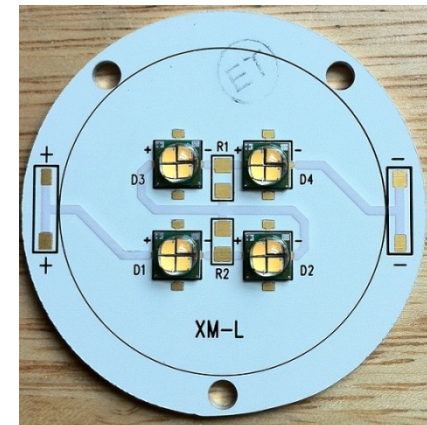

PCB Materials For LEDs

- Materials
 - Glass Epoxy FR4
 - Metal-Core
 - Many Varieties: Look closely at the specs
 - Flex Circuits
- LED Footprints
 - See supplier datasheets

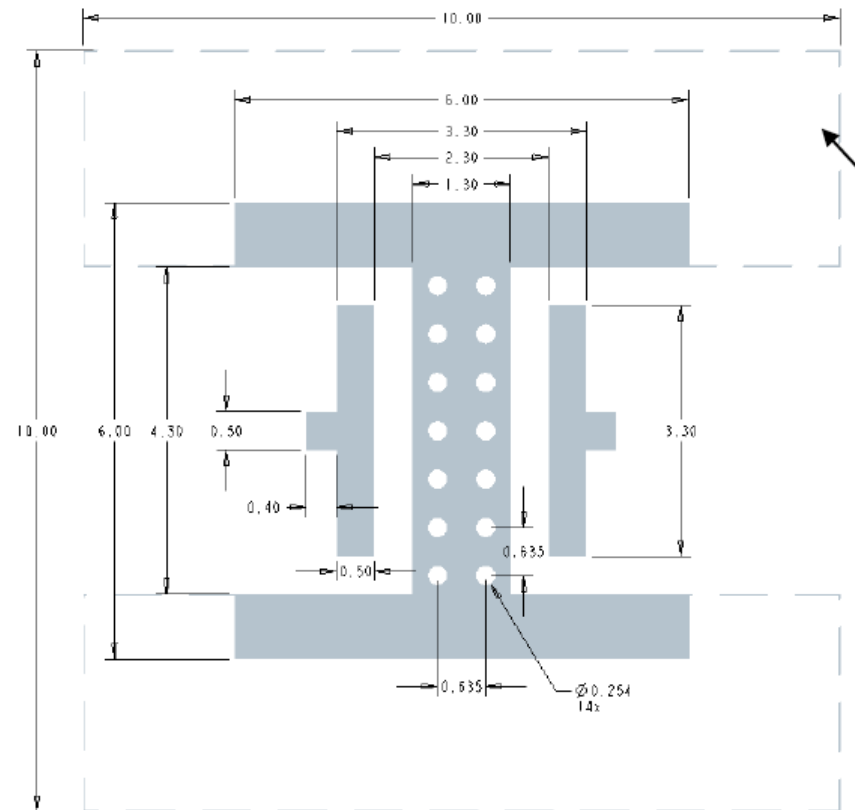



PCB Layout Guidelines - Partial

- Add “tab” (open solder mask) to measure solder point temperature
 - Add official temperature test point on board
- Design for High Voltage/Hi-Pot Tests
 - Add top-side clearance for screw head at earth ground
 - Creepage/Clearance around board edges
- Calculate Trace Widths on Primary Current Path
 - High Power LED currents will vary, design-to-design
- Consider Wire to Board Connectors/Terminals
 - Difficult to use solder pads in production
 - Your Lighting end-customer doesn’t own a soldering iron
 - Leave good copper area around connector to avoid lifting connector
- Tent/Fill vias on FR4 Designs to avoid solder flow to bottom of PCB



Conformal Coatings, Adhesives, Processing Residuals

- VOCs cause Degradation of LED's Primary Optic
- Direct Coatings will change optical performance
- Primary Cause: Sealed Enclosures with incompatible VOCs
- Follow LED Manufacturer's Guidelines
- Consult with Chemical Suppliers

“The presence of incompatible volatile organic compounds (VOCs) in LED illumination systems can accelerate the degradation or impair the performance of LEDs from any manufacturer.”

- Cree Chemical Compatibility Application Note

Optical Components

- Primary Optic
 - The LED Component Optic
- Secondary Optics
 - Lenses, Reflectors
 - Singular, Arrayed or Custom
 - Challenge:
 - Alignment and Attachment during Production
- Tertiary Optics
 - Sheet/Film/Formed Diffusers
 - Clear Covers

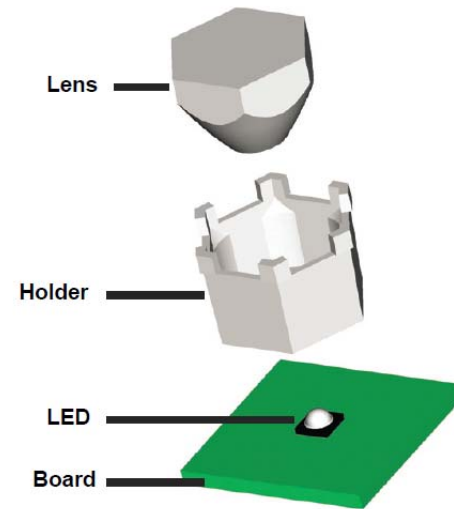

Courtesy of Polymer Optics



Courtesy of Fusion Optix

- Second Law of SSL Design:
“The optical system serves as the environmental barrier for the light engine”
- The “final” optic is an integral component for sealing the fixture



Secondary Optics

- Literally 1000s of SKUs available from various suppliers
- Types
 - TIR Lens
 - Reflectors
 - Hybrid
- Customized Parts available
 - Over-molded arrays
- Applications
 - Street Lighting to Spot Lights
- Challenges
 - Volume Manufacturing
 - Adhesives vs. Mechanical Mounting
 - Tolerance stack-up



Courtesy of Ledil



Courtesy of Carclo

Tertiary Optics

- Many choices available
 - Materials
 - PMMA, PC, PETG
- Formed Processes
 - Injection Molding, Vacuum Forming
- Light Shaping
- High Transmission Efficiencies
 - 80% to 90%

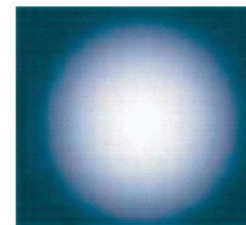
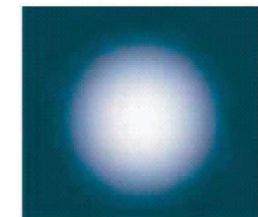
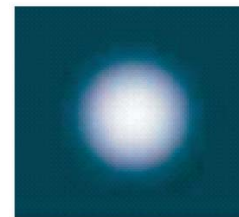
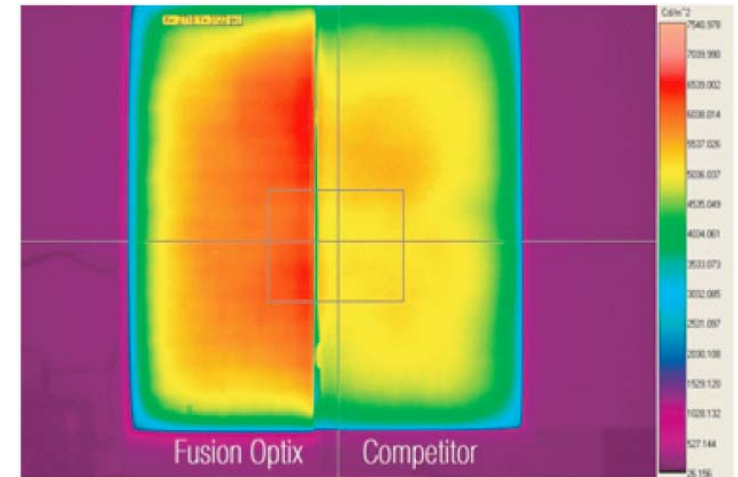

Optical Simulation

- Optical Simulation
 - Know in advance the expected results
- IES Files
 - Text file containing light source intensity distribution
 - Available for Light Fixture and Secondary Optics
 - Free/Low-Cost Viewer Tools Available
- Optical Modeling
 - Rayset files from LEDs
 - Simulates light travelling through out the system

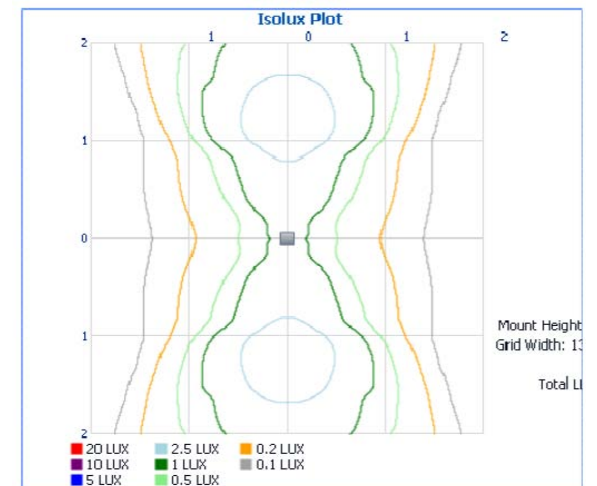
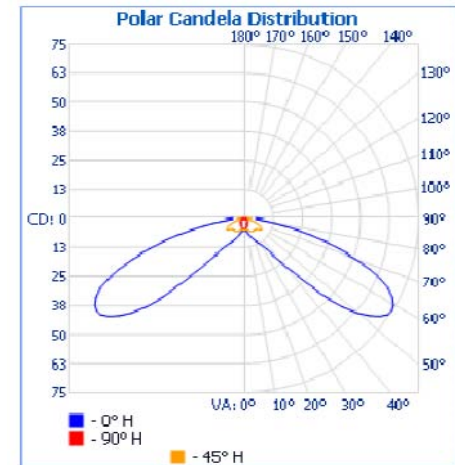

Courtesy of Photometrics Pro

Avoiding Optical System Pitfalls

- Invest in learning lighting terminology
 - Illuminance (Lux, foot-candles)
 - Luminous Flux (lumens)
 - Intensity (candela)
- “Clear” Covers add optical losses
 - ~8% Fresnel Loss
 - **Much greater at high incident angle**
- Ultra Violet Radiation
 - Review materials for UV resistance
 - Discoloration
- **Perform tolerance stack up analysis to determine actual performance of secondary optical system**
- **Significant body of privately held IP exists relative to optics particularly related to mass production manufacturing processes to address alignment, attachment, and environmental barrier requirements**



Courtesy of Polymer Optics

Thermal Components

- Third Law of SSL Design:
“The Enclosure is the Heat Sink”
 - Avoid mounting traditional heat sinks in sealed enclosures
- Moves the heat generated by the LEDs to the ambient
- Thermal relief for the LEDs and the Power Supply



Third Law Example

- “Heat Sink” (Enclosure) serves functional and aesthetic roles in design
- Power supply may have separate location or thermal path
- Note: Product operation presumes access to air ambient



Courtesy of VaOpto

Simple Thermal Model

- Performance and Life of the LED depends on junction temperature
- Current passing through the LED generates heat
 - ~20% to Light Energy
 - Remainder: Thermal Energy
- Thermal Resistance
 - Lower is better
 - Increase surface area of all thermal paths and elements
- Conduction, Convection and Radiation

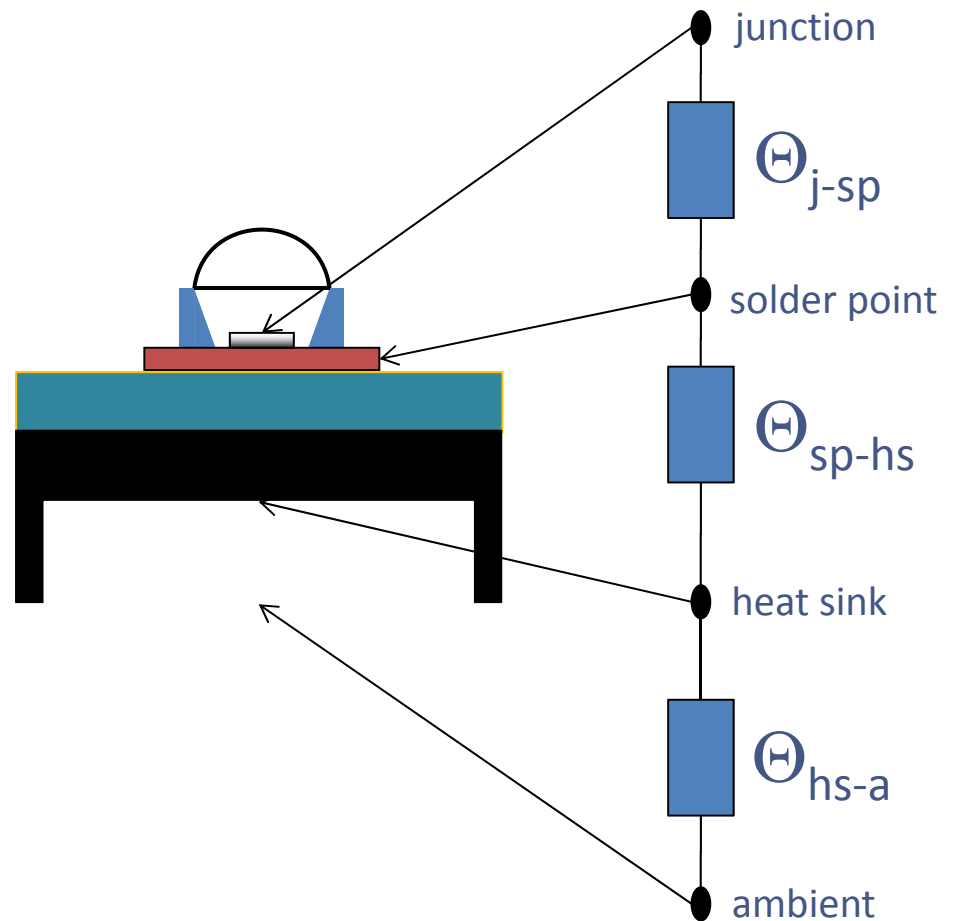

Thermal Materials – Conduction, Convection, Radiation

- Thermal Interface Materials
(Conduction)
 - Thermal connection between two distinct mechanical components
 - Thermal Pastes, Adhesives, Adhesive Pads and Foam/Gap Pads
- Enclosures
(Convection and Radiation)
 - Increase Surface Area
 - Evaluate Surface finishes for emissivity
 - Painted surfaces perform well
 - Balance against environmental safeguards



Power Supply Strategy

- LEDs require current regulation (instead of voltage regulation)
 - Light proportional to Current

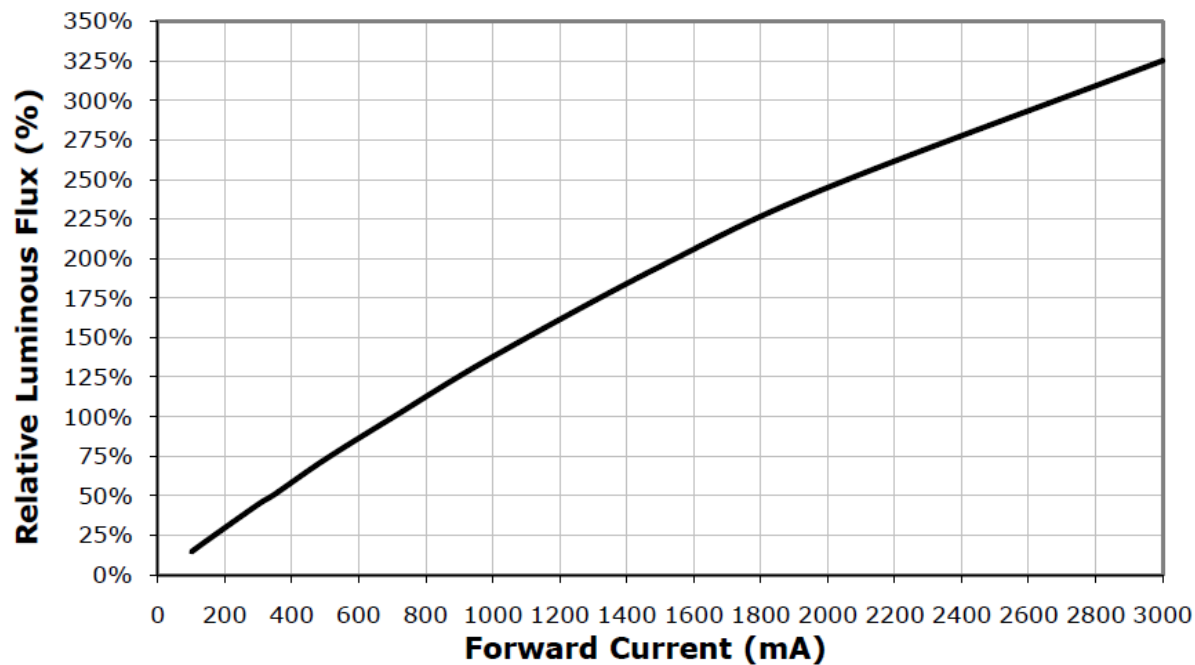

Selection Decision: Off-the-Shelf vs. Custom

- SSL Lighting Market Significantly Biased Toward off-the-shelf solutions
 - Includes Enclosed and Open Frame
 - Spreads Engineering and Agency costs across more units
 - Marketplace provides many options
 - Electronic design expertise uncommon in Lighting Fixture Market
- UL8750: Primary Approval for SSL Drivers
- Custom Solutions
 - Sufficient Volume To Justify Development Costs
 - Lowest Unit Cost (if volume is sufficient)
 - Much more common in Low Voltage DC Supplies



Selection Decision: Isolated vs. Non-isolated

- Most off-the-shelf supplies: Class 2 Isolated
 - Transformer Isolation
 - Least risk for Electrical Shock and Fire
- Non-Isolated Design: Potential Benefits
 - Lower Supply Cost (Fewer Components)
 - Smaller Size
 - Greater Efficiency
- Non-Isolated Design: Consequences
 - Flame Ratings Required on Fixtures
 - **Do not select optical material prior to making this decision**
 - Normally PMMA (Acrylic) is off the table
 - Must Provide Physical Barrier to High Voltage
 - Human Contact
 - Enclosure Isolation



Courtesy of NXP



Selection Decision: Constant Voltage vs. Constant Current

- Constant Voltage: Only used when another current regulation element exists in the design
 - Distributed DC Converters
 - Advantages
 - Architecture tends to regulate current effectively in individual strings
 - Light-engine is a low voltage component (agency advantage)
- Constant Current
 - Provides current regulation and power conversion from primary supply source
 - Difficult to accurately control current in parallel strings
 - Add low value resistors in each string
 - All strings should share common thermal plane
 - Thermal feedback from higher current strings will help regulate current

Constant Current/Constant Voltage Supplies

- SSL Drivers with current and voltage regulation
 - Limits maximum voltage (open circuit voltage) in current regulation designs
 - Limits maximum current on voltage regulation designs

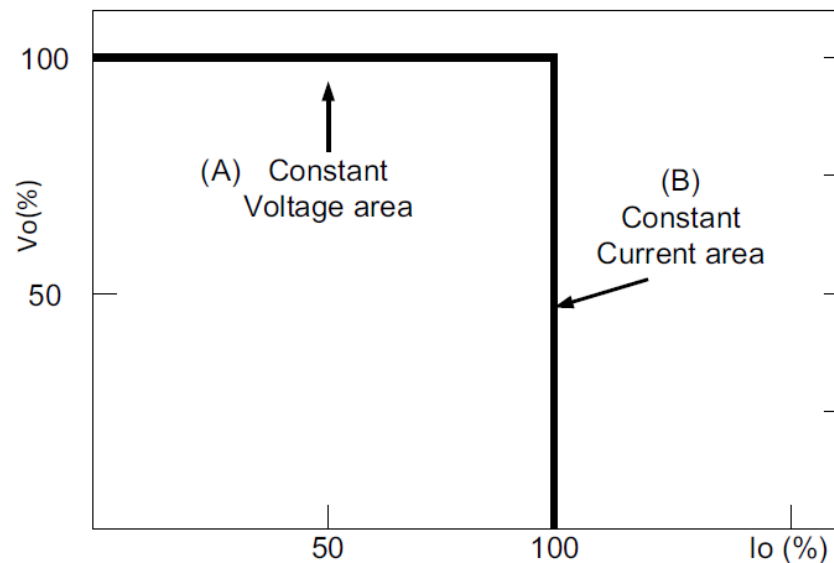

Typical LED power supply I-V curve



Dimmable Drivers

- Two Primary Dimming Techniques
 - TRIAC (Phase)
 - 0V to 10V Dimming
- Not a default feature in all supplies
- TRIAC Dimming supplies tend toward 20 Watts or less
 - Test dimmers to assure operation across dimming range
 - Dimmer may require minimum load (more than one fixture)

- Verify Surge Protection Requirements
 - Different between Residential, Commercial, Industrial and Outdoor
- Governing Classifications/Standards
 - ANSI C62.41 Class XX
 - UL1449: Safety and Performance Standards
- Energy Star includes surge testing requirements



Avoiding Power Supply Pitfalls

- Hot Plugging
 - Occurs when current regulated supply is powered on prior to connection to LEDs
 - Review manufacturing flow/test procedures to avoid
- The power supply is part of the thermal design
 - Look for designated Tc on Case
 - Power Supply largely determines the fixture life
- Understand Thermal Failure mode
 - “Burn-Out” may be preferable to Flashing
- PFC: Power Factor Correction (and other small print)
 - Look for key electrical specs beyond current and voltage
- Current Regulation
 - Lighting does not require tight (1%) current regulation
 - 20% not uncommon: cost savings

- The Three Last Things: Death, Taxes and Agency
- Maintain “Design for Agency Testing” mentality through-out the design
- Do not under-estimate the influence of Agency requirements
 - UL is in the DNA of the Lighting Industry

Agency Examples (Partial)

Standard	Draft	Comment	Comment Resolution	Publication Status
IES RP-16 <i>Definitions</i>	X	X	X	Complete
ANSI BSR C78.377A, <i>Chromaticity</i>	X	X	X	Complete
IES LM 79, <i>Luminous Flux</i>	X	X	X	Complete
IES LM 80, <i>Lumen Depreciation</i>	X	X	X	Complete
NEMA LSD-44, 45, 49 (White Papers) <i>Best Practices for SSL Interconnect, Sub-Assemblies, Dimming</i>	X	X	X	Complete
ANSI C82.77, <i>Harmonic Emission Limits – Related Power Quality Requirements for SSL</i>	X	X	X	Complete
NEMA SSL-1, <i>SSL Drivers</i>	X	X	X	Complete
NEMA SSL-3, <i>LED Lamp Binning</i>	X	X	X	Complete
NEMA SSL-6, <i>Dimming Practices for SSL Integrated Lamps</i>	X	X	X	Complete
NEMA-ALA Joint White Paper <i>Definition of Functional & Decorative Lighting</i>	X	X	X	Complete
UL 8750 <i>LED Safety</i>	X	X	X	Complete
IEC 62471-2, IES RP-27 <i>Photobiological Safety</i>	X	X	X	Complete
CIE TC1-69, <i>Color Quality System</i>	X			
IES TM-21 <i>LED Lifetime</i>	X	X	X	Complete
47 CFR Part 15 (FCC) <i>Radio Frequency Emissions for SSL Components, Drivers</i>	X	X	X	Complete
IEC 62471-2, IES RP-27 <i>Photobiological Safety</i>	X	X	X	Complete



Governmental/Industry Organizations

- Energy Star
 - Now Under Environmental Protection Agency
 - Energy Star Marking for Specific Products
- Department of Energy EERE
 - Energy Efficiency & Renewable Energy
 - Influencing SSL Fixture Development
 - Broad Concerns beyond SSL
 - Renewable Energy Sources, All Energy Efficiency Programs
- New: Design Lights Consortium
 - Qualified Products Listing
 - 16 Categories for SSL Fixture Target Specifications for Non-Residential Applications

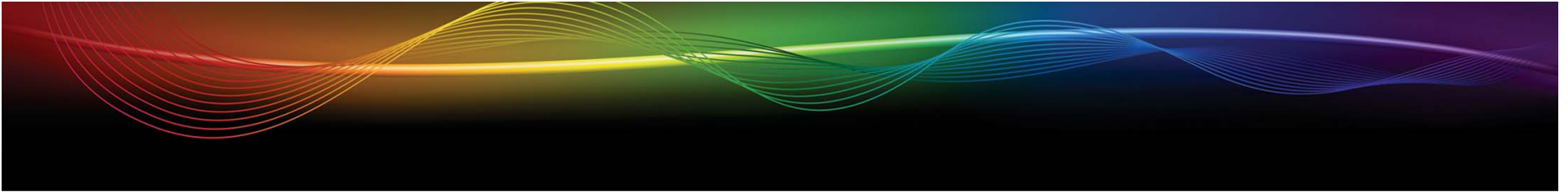

SSL Product Production



Moving to Production: Pilot Production

- First Step: Pilot Production (10s to 100s of units)
 - Field trial format not uncommon
 - Significant time gap between pilot production and mass production
 - Have realistic (conservative) expectations about mass production orders
 - Look out for other competition during this stage
 - Many players chasing the same piece of business
- Supply Chain
 - Only secure required components for pilot build
 - Specifications could change
 - Technology could improve
 - As confidence builds begin forecasting to suppliers
 - Communicate lead-times to end customer



Semiconductor Supply Chain

- Semiconductor Supply Chain Realities
 - Lighting Market has a “Build to Order” nature
 - There’s no forecasted demand until order placed (broad, best-case, estimates only)
 - Common Lead-Time Expectation: Stock to 4 weeks
 - Semiconductor Component Lead Time: Stock to 12 Weeks (or longer)
 - Applies for Light Engine and Power Supply components
 - Add Light Engine and Power Supply manufacturing time for actual lead time
- Hopeful about improvement once market size increases

LED Supply Chain

- Maintain modest in-house stocking position or bonded inventory with distributor in component form for quick order response
- Reminder: Binning Flexibility = Availability
- Avoid putting LEDs on PCBs prior to orders
 - Keep on-hand inventory in approved packaging

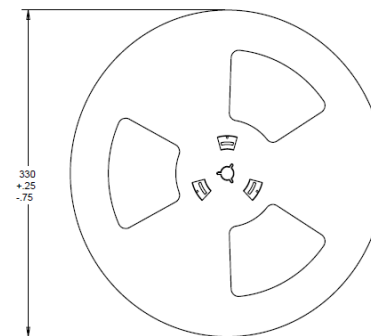
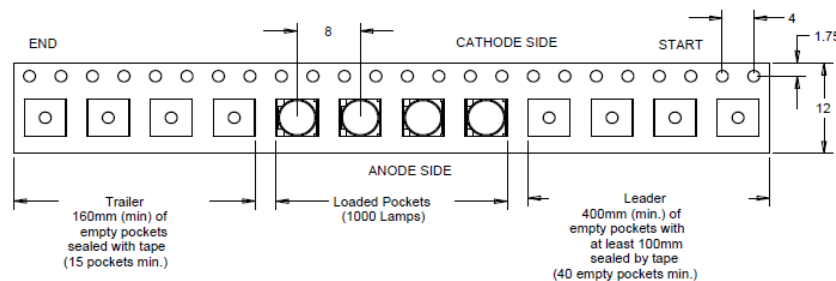



Supply Chain: Other Components

- Many SSL Components Share LED Distribution Channel
- Optic component availability
 - Many optic SKUs leads statistical challenge for stocking through distribution
 - Treat as a custom component
- Power Supply Availability
 - Many SKUs, high value
 - Difficult for distribution to support without forecast/commitments
 - Verify lead-time on your model
 - Remember: Power Supplies are subject to semiconductor market forces
 - Treat as a custom component



SSL Design Check List

- Verify authenticity of application
- Educate end-customer
- Validate Lighting Specifications
- Balance Design Elements
 - Light
 - Optics
 - Power
 - Thermal
- Proof on Concept Unit
- Select the LED with the capacity that matches the application
- 1st Law: New Fixture = New PCBA
- 2nd Law: The Optic Protects the Light Engine
- 3rd Law: Enclosure = Heat Sink
- Power Supply
- Agency
- Supply Chain



Conclusions

- Never take for granted that the LED is a diode
 - The semiconductor and related technology industries have a historical opportunity to address an entirely new market
 - Success in the past with other technology revolutions of the past 30 years (PC, Cellular, Communications, Internet, Embedded Controls, etc.) doesn't guarantee the industry is properly configured to effectively address the lighting market
- Firms need to review own strengths and develop plan, possibly reconfigure/change, to address the lighting market
- Lighting market/industry will adjust also to the new technology



SSL Lighting Future

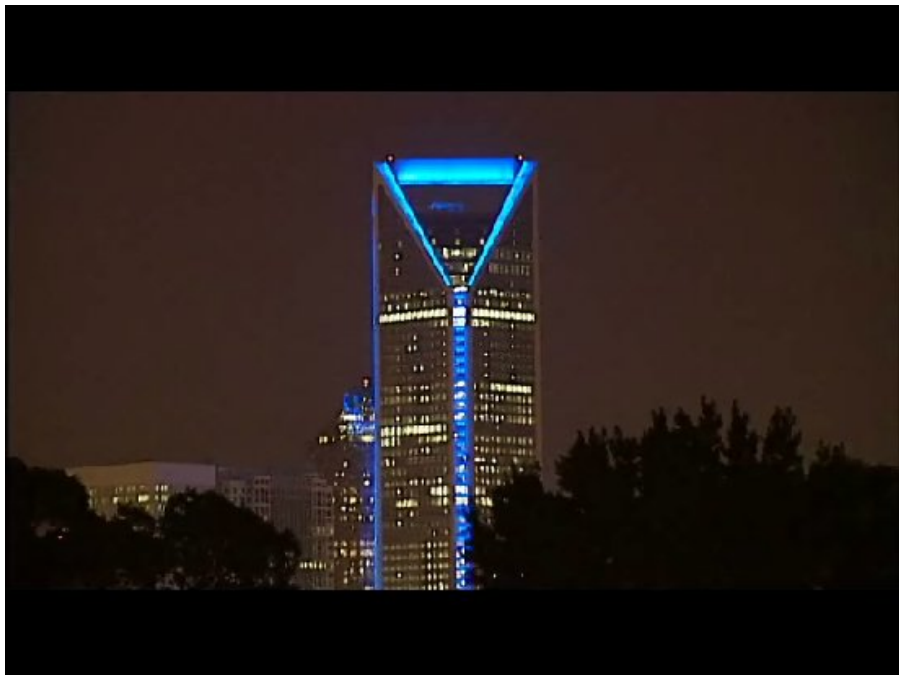



Thank You

Questions?